

# EM

## Electrical Manual

**SCU/4**  
**616054-0150**

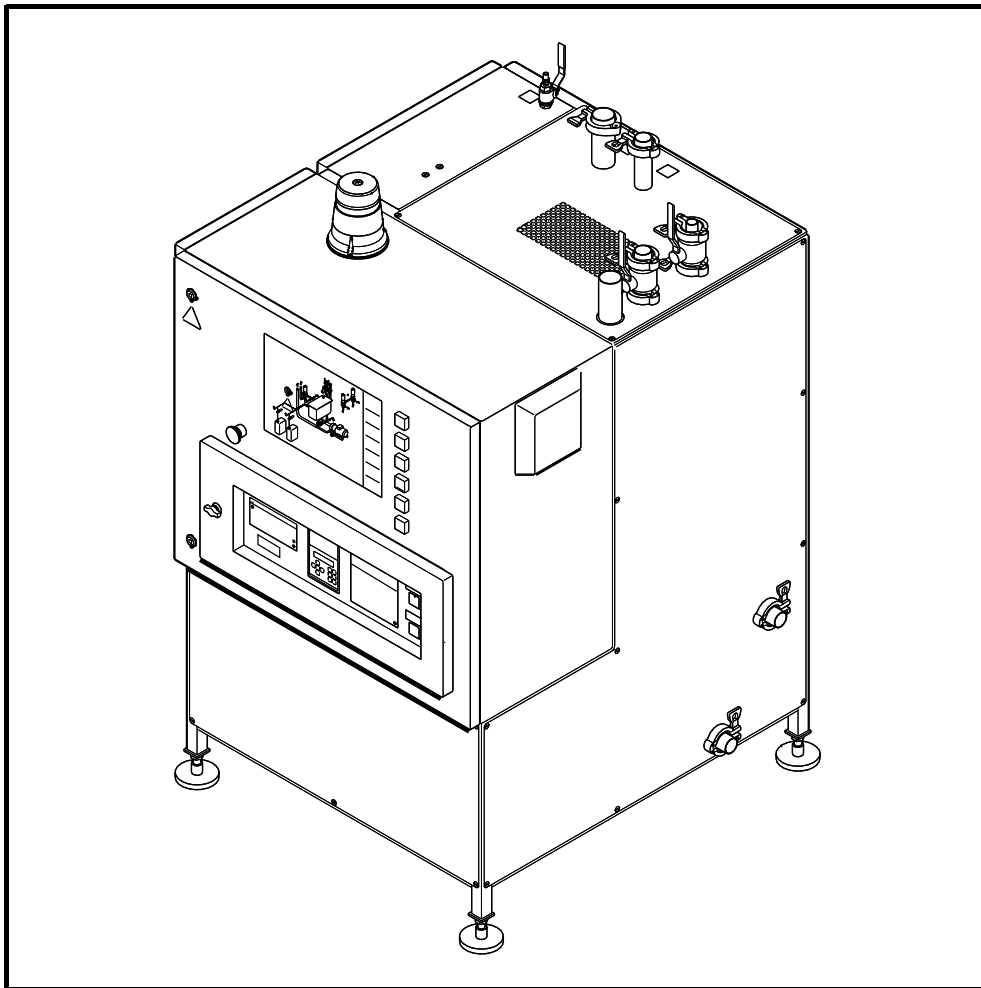

TechPub\_2614345\_0103 - EM\_2890021\_0101fro.fm



### **WARNING**

**Read and follow all safety precautions before working on or near this equipment.**

Read all safety precautions throughout this manual and on safety signs attached to this equipment. Failure to follow all safety precautions could result in death or serious injury.



Doc. No. EM-2890021-0101

Copyright © 2007 Tetra Pak Group

All rights reserved. No part of this document may be reproduced or copied in any form or by any means without written permission from Tetra Pak Packaging Solutions.

 **Tetra Pak** and all Tetra Pak products are trademarks belonging to the Tetra Pak Group.

The content of this manual is in accordance with the design and construction of the machine or equipment at the time of publishing. Tetra Pak reserves the right to introduce design modifications without prior notice.

This document was produced by:

Tetra Pak Packaging Solutions  
Via Delfini, 1  
41100 Modena  
Italy

Additional copies can be ordered from Tetra Pak Parts or the nearest Tetra Pak office. When ordering additional copies, always provide the document number. This can be found in the machine specification document. It is also printed on the front cover and in the footer on each page of the manual.

Doc. No. EM-2890021-0101

Issue 2007-05

This manual is valid for:

Series No./ Machine No.

Sign.

# EM

## Electrical Manual

SCU/4  
616054-0150

TechPub\_2614345\_0103 - EM\_2890021\_0101fro.fm

A list of all optional equipment, optional kits, and rebuilding kits that this manual is valid for is found on the next page.

Doc. No. EM-2890021-0101

Issue 2007-05

 **Tetra Pak**

**Tetra Pak Packaging Solutions**

- i Introduction
- ii Safety Precautions
- 1 Electrical Systems Description
- 2 Document List
- 3 Position Summary
- 4 Circuit Diagrams
- 5 Line Summary
- 6 Cabinet Terminal Summary
- 7 Terminal Strip Overview
- 8 Cable Connection List
- 9 Mains Connections
- 10 Drawing Remarks
- 11 Engineering Change Description
- 12 Component Location
- 13 Other Information

## **Valid for:**

SCU/4  
616054-0150

From T-order: 22343/00001

EI. ECM No.: 303931





# i Introduction

## About the Introduction Chapter

This chapter contains basic information about this manual and the related Tetra Pak equipment.

**Abbreviations and Terminology . . . . . i - 5**

**Manual Information . . . . . i - 6**

    Delivered Manuals . . . . . i - 6

    Page Layout . . . . . i - 7

    Page Numbering. . . . . i - 8

    Typographical Conventions . . . . . i - 8

    Symbols . . . . . i - 8

**Machine Introduction . . . . . i - 9**

    Intended Use of the Equipment . . . . . i - 9

    Manufacturer . . . . . i - 9

    Support and Feedback . . . . . i - 9

**Identification . . . . . i - 10**

    CE Classification . . . . . i - 10

    Machine Plate . . . . . i - 10

**Orientation . . . . . i - 11**

**How to Use This EM . . . . . i - 12**

    Numbering System for Components . . . . . i - 14

        Location Designation . . . . . i - 14

        Function Designation . . . . . i - 14

        Running Number . . . . . i - 14

    How to Trace an Electrical Component . . . . . i - 15

        Example 1: How to Trace a Line . . . . . i - 15

        Example 2: How to Trace a Contactor . . . . . i - 17

        Example 3: How to Trace  
        a Terminal in the Electrical Cabinet . . . . . i - 18

        Example 4: How to Trace a Terminal  
        Outside the Electrical Cabinet . . . . . i - 19

        Example 5: How to Find Electrical Components  
        Using the SPC . . . . . i - 20

TechPub\_2614345\_0105 - EM\_2890021\_0101int.fm

This page intentionally left blank

TechPub\_2614345\_0105 - EM\_2890021\_0101.int.fm

## Abbreviations and Terminology

Abbreviation/ Terminology	Meaning	Translation
CE	Communautés Européennes/European Communities	
EM	Electrical Manual	
MM	Maintenance Manual	
OM	Operation Manual	
SDS	Safety Data Sheet	
SPC	Spare Parts Catalogue	
TPMS	Tetra Pak Maintenance System	

## Manual Information

Tetra Pak recommends reading all delivered manuals carefully. Make sure that the delivered manuals are available to personnel who operate or maintain the equipment.

It is important to keep this manual for the lifetime of the equipment and to pass the manual on to any subsequent holder or user.

Tetra Pak will not be held responsible for any damage to the equipment caused by not following the instructions given in this manual.

## Delivered Manuals

Manuals delivered with this equipment:

- EM  
The Electrical Manual provides technicians with information about the equipment's electrical system.
- MM  
The Maintenance Manual provides technicians with information on maintaining the equipment.
- OM  
The Operation Manual manual provides the operator with information on handling and operating the equipment before, during, and after production.
- SPC  
The Spare Parts Catalogue provides the information necessary to order spare parts from Tetra Pak

## Page Layout

Every main page in a manual contains a header and a footer. The page header contains the chapter name (1) and the section name (2). The page footer contains the page number (3), and the document number (4). See also the Page Numbering section.

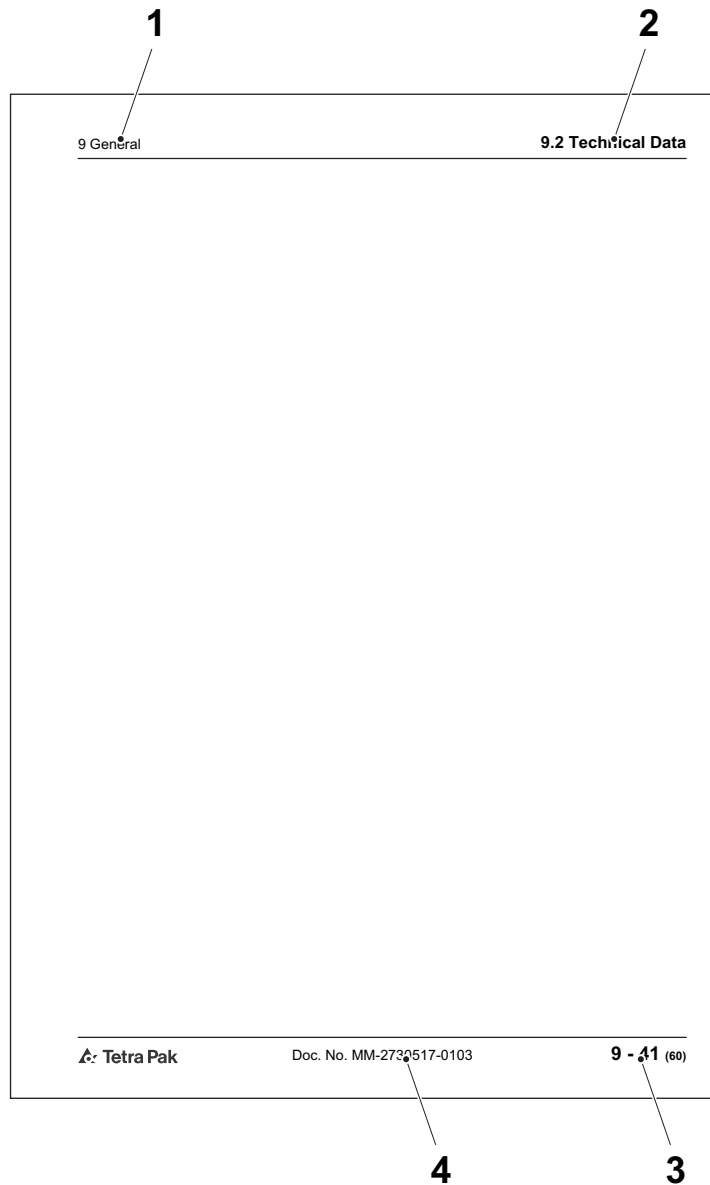

- 1 Chapter name
- 2 Section name
- 3 Page number
- 4 Document number

TechPub\_2614345\_0105 - EM\_2890021\_0101int.fm

## Page Numbering

A page number has three parts:

- chapter number (1)
- consecutive page number (2) within the chapter
- total number of pages (3) in the chapter.

**4 - 11 (18)**

↑      ↑      ↑

**1      2      3**

- 1 Chapter number
- 2 Consecutive page number
- 3 Total number of pages





## Typographical Conventions

Controls on the operator panel, emergency stop devices, and program steps are printed in CAPITAL LETTERS.

Cross-references are underlined.

## Symbols

Symbols used in illustrations.

	A pointer arrow indicates the position of an object.
	A zoom arrow indicates that an object view is enlarged. The arrow points towards the enlarged view of the object.
	A rotation movement arrow indicates rotational movement of an object. The arrow points in the direction of rotation.
	A straight movement arrow indicates movement of an object. The arrow points in the direction of movement.

# Machine Introduction

## Intended Use of the Equipment

The intended use of this Tetra Pak equipment is to clean product valves and filling pipes of Tetra Brik Aseptic filling machine.

All other use is prohibited. Tetra Pak will not be held responsible for injury or damage if the equipment is used for any other purpose.

## Manufacturer

This Tetra Pak equipment has been manufactured by

Tetra Pak Packaging Solutions  
Via Delfini, 1  
41100 Modena  
Italy

## Support and Feedback

If you encounter problems when operating this equipment or have other inquiries, comments, or suggestions for improvement, contact Tetra Pak.

# Identification

## CE Classification

This equipment complies with the basic health and safety regulations of the European Economic Area (EEA).

## Machine Plate

The illustration below shows an example of the machine plate and its location on the equipment. The machine plate carries data needed when contacting Tetra Pak concerning this specific equipment.

Make sure that the equipment data in the front pages of this manual corresponds to the machine plate data and the machine specification.

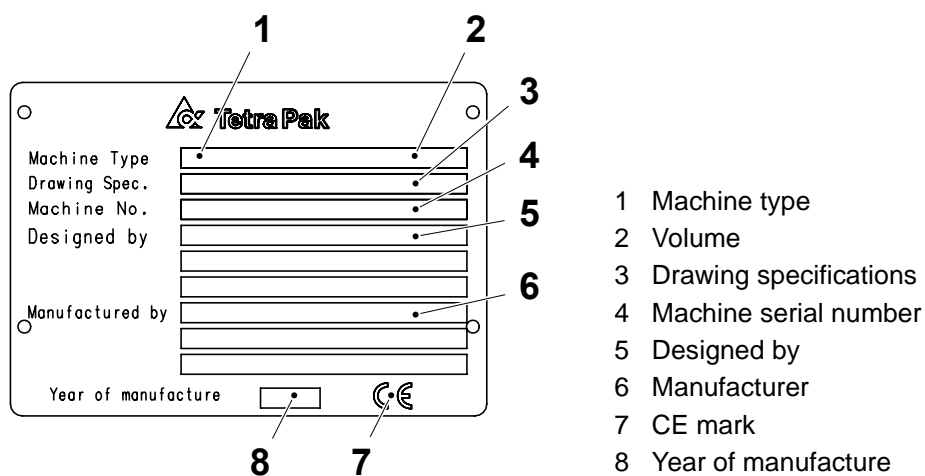
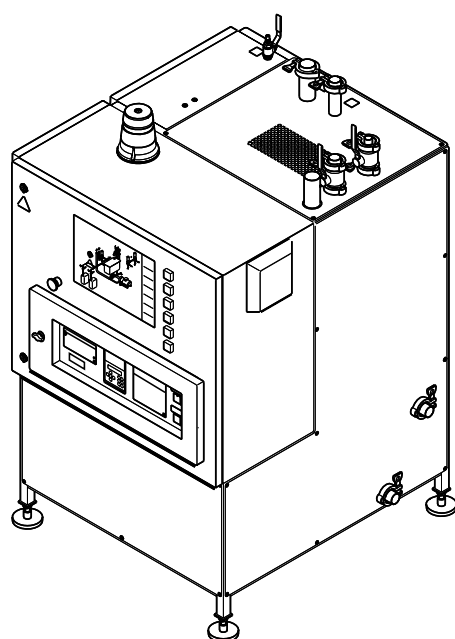

- 1 Machine type
- 2 Volume
- 3 Drawing specifications
- 4 Machine serial number
- 5 Designed by
- 6 Manufacturer
- 7 CE mark
- 8 Year of manufacture

TechPub\_2614345\_0105 - EM\_2890021\_0101int.fm

# Orientation

The illustration below shows the orientation of the equipment. This orientation information will be used throughout this manual. The arrows indicate the flow of material.

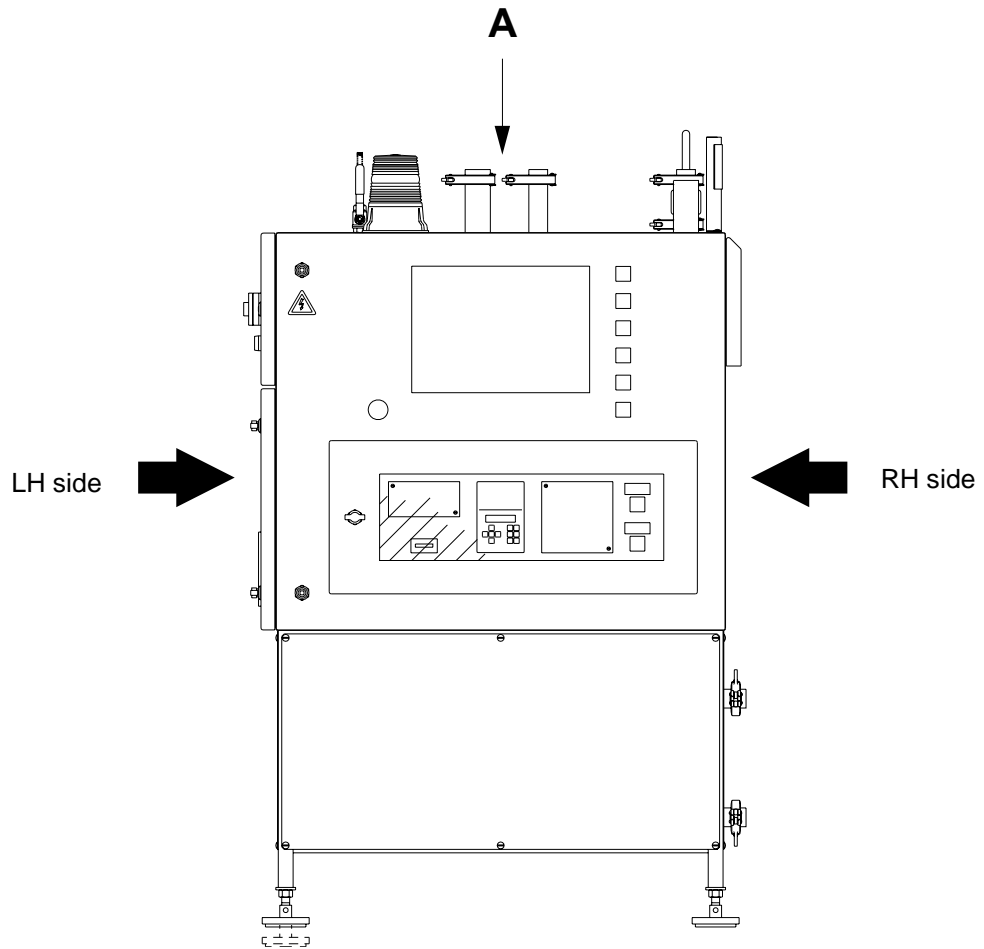

TechPub\_2614345\_0105 - EM\_2890021\_0101int.fm

## How to Use This EM

Chapters in this EM.

Chapter	Name	Drawing No.
i	Introduction	
ii	Safety Precautions	
1	Electrical Systems Description	
2	Document List	2895133-0001
3	Position Summary	2895133-0002
4	Circuit Diagrams	2895133-0003
5	Line Summary	2895133-0004
6	Cabinet Terminal Summary	2895133-0005
7	Terminal Strip Overview	2895133-0006
8	Cable Connection List	2895133-0007
9	Mains Connection	2895133-0008
10	Drawing Remarks	2895133-0098
11	Engineering Change Description	2895133-0099
12	Component Location	
13	Other Information, for exemple -Bills of Material -Fuse Panel Labels	

The Document List chapter is a table of contents for the chapters 3 to 9, listing all drawings included.

In the Circuit Diagrams, the first pages are reserved for distribution terminals and the last pages can be used for pre-connected cables. Pre-connected cables are connected to spare terminals and are reserved for future use.

The diagrams in the Mains Connection chapter shows how the machine should be connected to the local supply, the dimensions of the connection cable, and the connection of the matching transformer, when used.

The Drawing Remarks chapter lists the drawing remarks indicated with a number in the drawing.

*(Cont'd)*

(Cont'd)

The documents and drawings are identified by drawing number (1), version code (2), and page number (3). The page number is the consecutive numbering of the pages that belong to the main number and is used as a reference in the diagrams.

Date	2002-07-31	Machine	PT21-0600		
Denomination	CIRCUIT DIAGRAM		Page Type INFEED MOTOR		
Document No.	2557519-0003	Doc. type	ELD	Version	AA
				Page	.007

**1**

**2**

**3**

- 1 Drawing number
- 2 Version code
- 3 Page number

## Numbering System for Components

Components are identified by the a location designation (1), a function designation (2), and a running number (3).

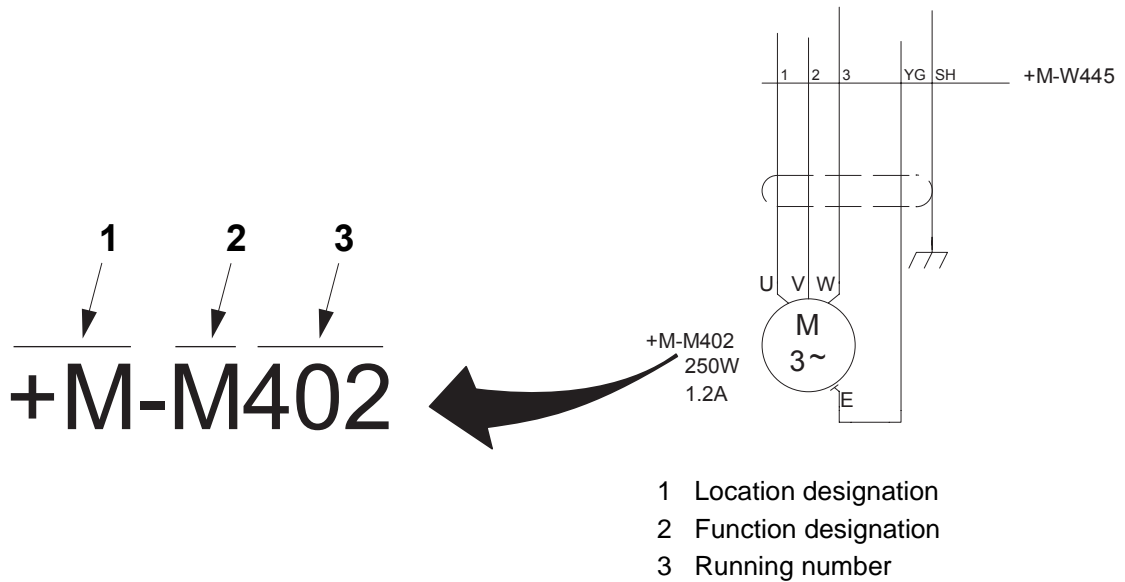

### Location Designation

The location designation shows the location of the component:

- +M indicates that the component is fitted on the machine, outside the electrical cabinet.
- +C indicates that the component is fitted on the electrical cabinet, on the TPOP, or on the process panel.

**Note!** The location +C is considered the default and is omitted on all Circuit diagram pages.

### Function Designation

The function designation is indicated in accordance with international standards.

Examples: Code P for components that present information, such as an alarm lamp, a clock, or a volt meter. Code M for components that provide mechanical energy such as an actuator, or an electric motor.

### Running Number

The electrical components are numbered in a consecutive non-logical order.

## How to Trace an Electrical Component

Start tracing an electrical component by finding the correct list with page and column references to the Circuit Diagram.

Example 1 on pages [i-15](#) to [i-16](#) illustrates how to trace a Line. Use the Line Summary.

Example 2 on page [i-17](#) illustrates how to trace a contactor. Find page references in the Position Summary. The procedure is identical when tracing sensors or other components. For cables, find the page references in the Cable Connection List. The number of spare cores is shown in the cable connection list.

Examples 3 and 4 on pages [i-18](#) to [i-19](#) illustrate how to trace a terminal. Find page references for terminals *in* the electrical cabinet in the Cabinet Terminal Summary, and page references for terminals *outside* the electrical cabinet in the Terminal Strip Overview.

Example 5 on page [i-20](#) illustrates how to locate a component in the Spare Parts Catalogue, SPC.

### Example 1: How to Trace a Line

#### Supply Voltage and Line Connection Order

The supply voltage in the electrical cabinet has power voltage and control voltage designations.

- Power voltage: lines with designations ending with 01 to 09, for example, L03 and L09
- Control voltage: lines with designations ending with 10 to 99, for example, L12 and L12

The line connection order is shown in the Line Summary.

(Cont'd)

(Cont'd)

How to Trace a Line

The illustration below shows how to trace line connection L20 from the component terminal -K905:A2 to -K906:A2.

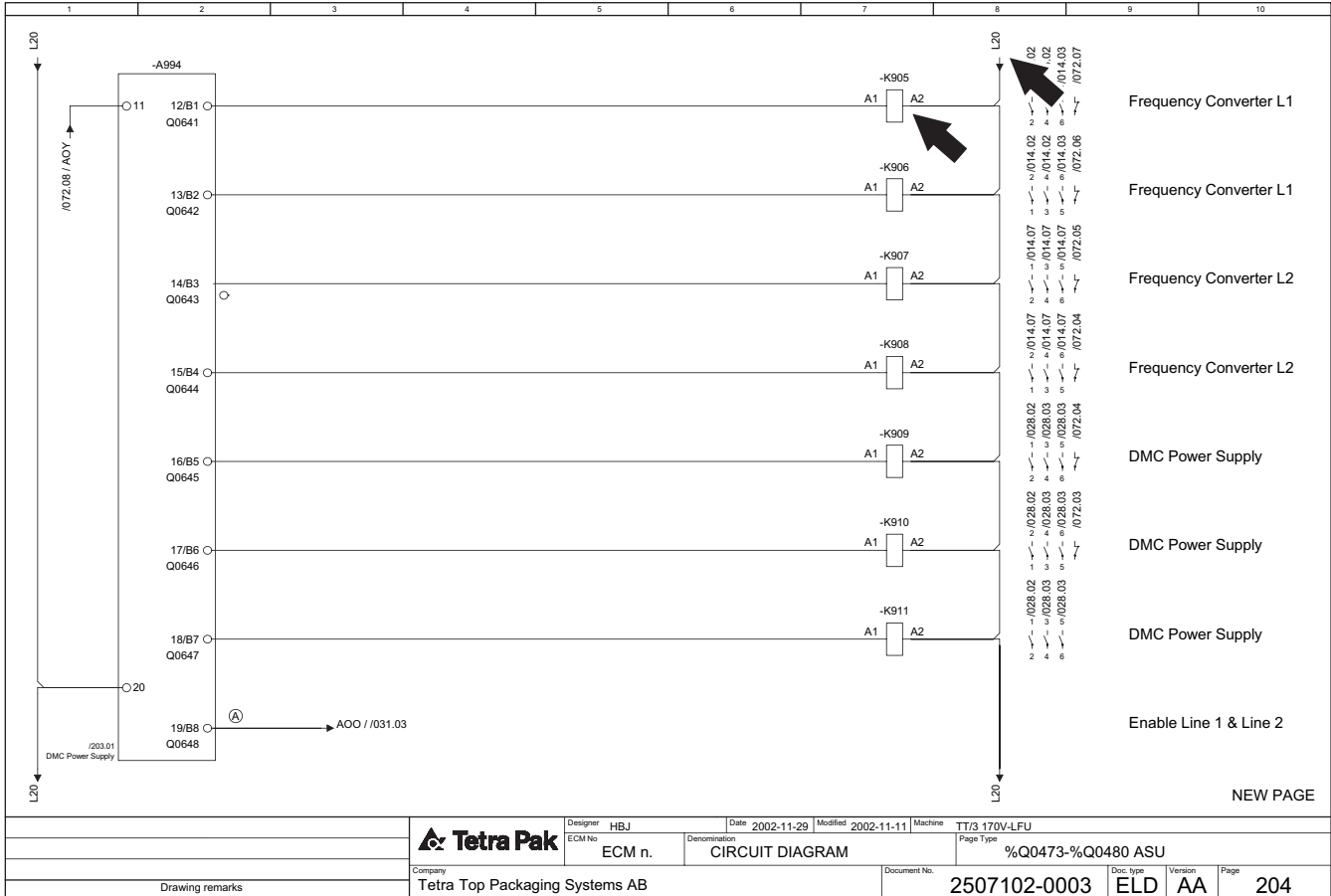

Line summary of 2507102-0003

Line	From	Page.Col.	To	Page.Col.	Area/Color	Opt.	Lin
L13	+C-XL013:25	001.8	+C-K087:8	068.6	0,75/ L.BU		
L13	+C-K087:8	068.6	+C-K088:8	068.6	0,75/ L.BU		
L13	+C-K088:8	068.6	+C-K053.1:7	076.6	0,75/ L.BU		
L20	+C-XL020:1	002.1	+C-K905:A2	204.7	0,75/ L.BU		
L20	+C-K905:A2	204.7	+C-K906:A2	204.7	0,75/ L.BU		
L20	-K906:A2	204.7	-K907:A2	204.7	0,75/ L.BU		
L20	+C-XL020:2	002.1	+C-G090:28	014.2	0,75 / BU		

TechPub\_2614345\_0105 - EM\_2890021\_0101int.fm

### Example 2: How to Trace a Contactor

The illustration below shows how to trace contactor -K109 to page 188, column 6 in the Circuit diagram.

Related contacts are traced with a cross reference to page 010, column 06, and to page 069, column 02.

**Note!** For master and slave components, such as coils and contacts, only the master is reported in the Position Summary. The slave shows the page and column references of the master.

Position summary of 2507102-0003			Position summary of 2507102-0003		
Component	Page .Col.	Opt.	Component	Page .Col.	Opt.
+C-G012	012 .5		+C-K108	074 .7	
+C-G013	012 .8		+C-K109	188 .6	
+C-G090	014 .2		+C-K111	188 .6	
+C-G091	014 .6		+C-K112	188 .6	
+C-G100	016 .2		+C-K001	149 .7	
+C-G101	016 .7		+OHP-K002		

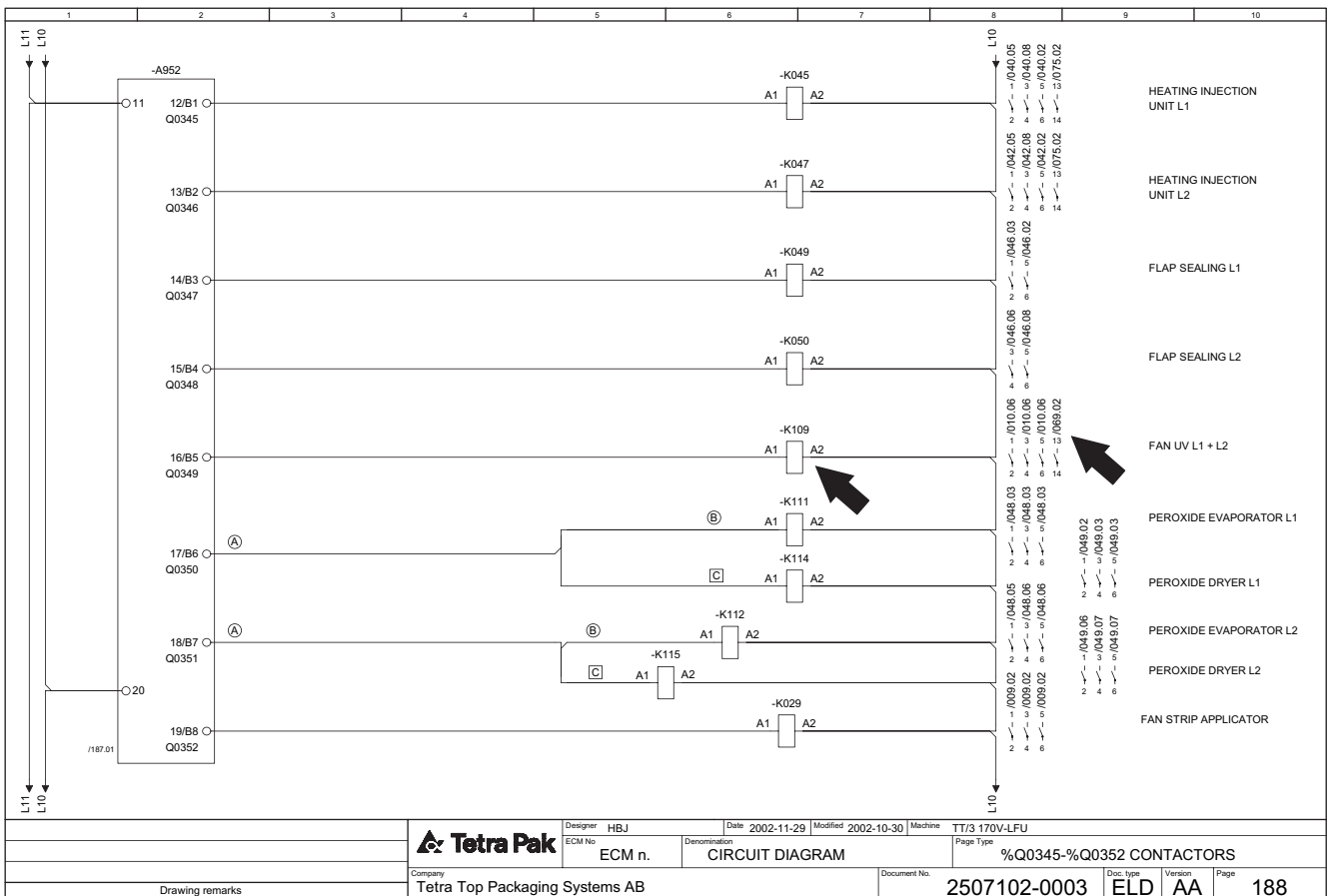

TechPub\_2614345\_0105 - EM\_2890021\_0101int.fm

### Example 3: How to Trace a Terminal in the Electrical Cabinet

The Cabinet Terminal Summary refers to the page and column where the relevant terminal is to be found.

The illustration below shows how to trace terminal +C-X004:76 to page 38, column 8 in the Circuit diagram.

Cabinet terminal summary of 2507102-0003	
Terminal	Page .Col. Opt.
+C-X004:75	038 .7
+C-X004:76	038 .8
+C-X004:77	
+C-X004:78	
+C-X004:79	039 .2
+C-X004:80	039 .3
+C-X004:81	039 .4
+C-X004:82	039 .6

Terminal	Page .Col. Opt.
+C-X004:103	042 .8
+C-X004:104	042 .9
+C-X004:105	043 .5
+C-X004:106	043 .6
+C-X004:107	043 .8
+C-X004:108	043 .9
+C-X004:109	
+C-X004:110	046 .2

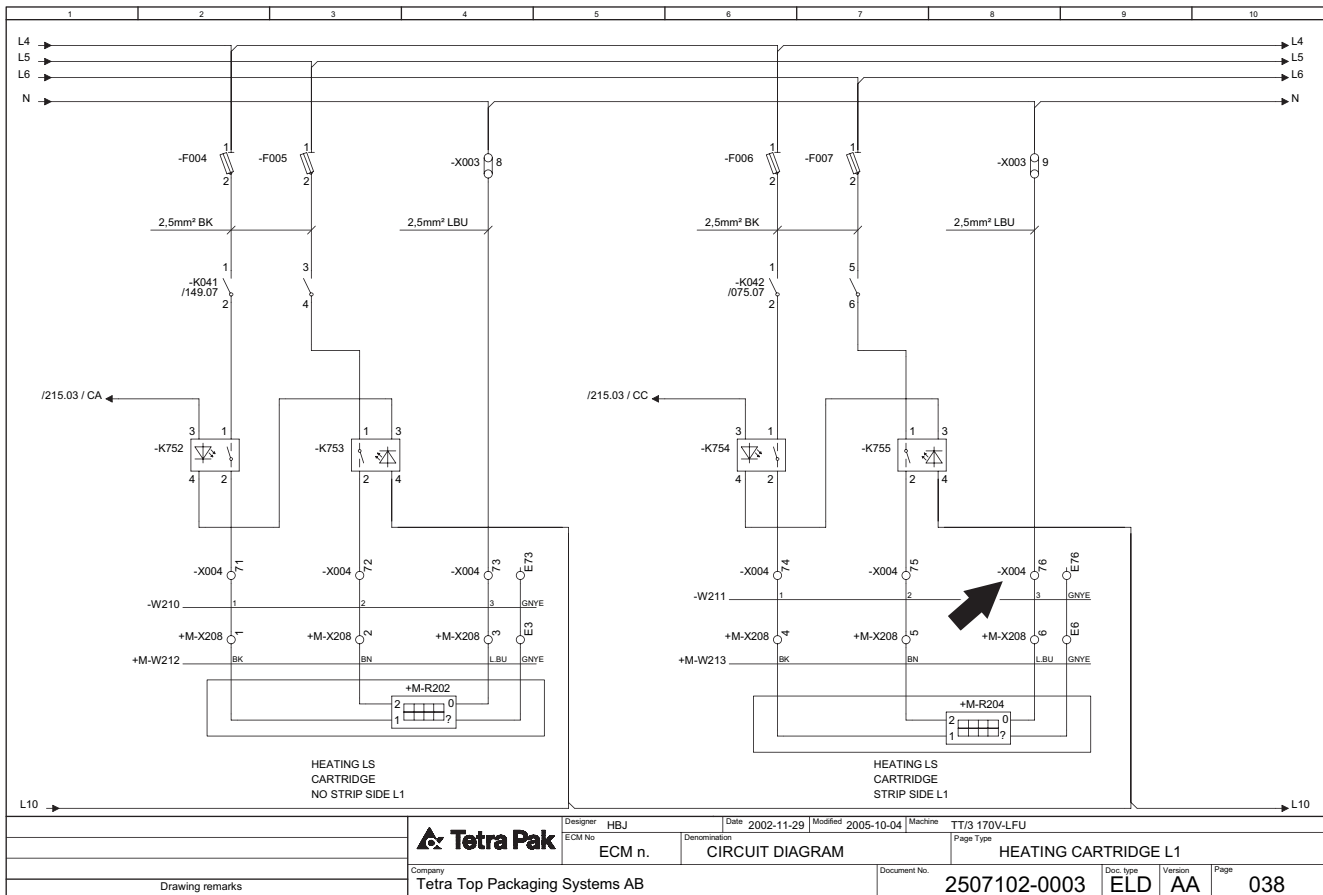

TechPub\_2614345\_0105 - EM\_2890021\_0101.int.fm

### Example 4: How to Trace a Terminal Outside the Electrical Cabinet

The Terminal Strip Overview refer to the page and column where the relevant terminal is to be found.

The illustration below shows how to trace terminal +M-X208:4 to page 038, column 6 in the Circuit diagram. Note the connected component, +M-R204:1.

Terminal strip of 2507102-0003									
+M-X208									
From	Cable	Terminal	External Jumper	Cable	To	Page.Col.	Option	Function text	
+C-X004:71	-W210:1	1		-W212:BK	+M-R202:1	038.2			
+C-X004:72	-W210:2	2		-W212:BN	+M-R202:2	038.3			
+C-X004:73	-W210:3	3		-W212:L.BU	+M-R202:0	038.4			
+C-X004:E73	-W210:GNYE	E3		-W212:GNYE	+M-R202:?	038.4			
+C-X004:74	-W211:1	4		-W213:BK	+M-R204:1	038.6			
+C-X004:75	-W211:2	5		-W213:BN	+M-R204:2	038.7			
+C-X004:76	-W211:3	6		-W213:L.BU	+M-R204:0	038.8			
+C-X004:E76	-W211:GNYE	E6		-W213:GNYE	+M-R204:?	038.9			

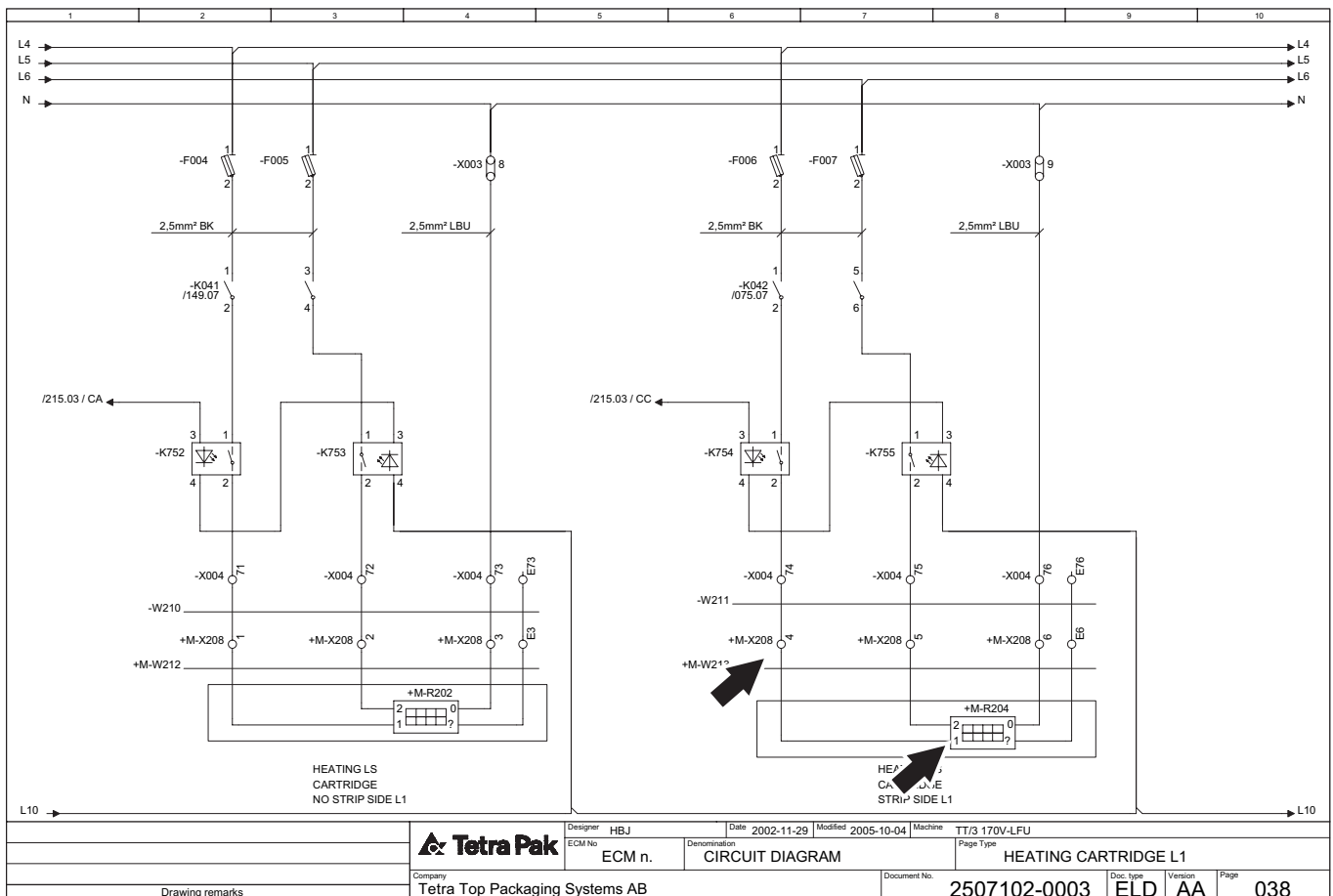

TechPub\_2614345\_0105 - EM\_2890021\_0101int.fm

		Designer: HBJ ECM n.: ECM n. Company: Tetra Top Packaging Systems AB	Date: 2002-11-29 Denomination: CIRCUIT DIAGRAM Document No.: 2507102-0003	Modified: 2005-10-04 Machine: TT/3 170V-LFU Page Type: HEATING CARTRIDGE L1	Doc. type: ELD Version: AA Page: 038
--	--	--	---	---	--

### Example 5: How to Find Electrical Components Using the SPC

The Reference Designation Parts Index in the Spare Parts Catalogue, SPC, is used to locate electrical parts. For SPCs without an Electrical Parts Index, see the Component Location chapter in this manual.

The illustration below shows how to find component B8405 in the SPC. The Reference Designation Parts Index refers to page 213. In the drawing on page 212, the position number is the same as the reference designation for the component.

B8202 ... 90459-0672	..... PROXIMITY SENSOR E2E2-X5MB1-5M	..... 21, 23	F8215 ... 9000'
B8401 ... 90444-0139	..... KEY SAF.SW. AZ16-02 ZVR K-2254	..... 213	F8216 ... 9000'
B8402 ... 90444-0139	..... KEY SAF.SW. AZ16-02 ZVR K-2254	..... 177	F8217 ... 9000'
B8403 ... 90444-0139	..... KEY SAF.SW. AZ16-02 ZVR K-2254	..... 247, 249	F8218 ... 9000'
B8405 ... 90044-0194	..... PROX.SW. IN5329/IN3002-BPKG	..... 213	F8250 ... 9000'
B8411 ... 90232-0123	..... PH.CELL WLL170-P135-6011723	..... 73, 75	F8252 ... 9000'
B8411 ... 90232-0325	..... FIBRE E32-DC200	..... 81	F8253 ... 9000'

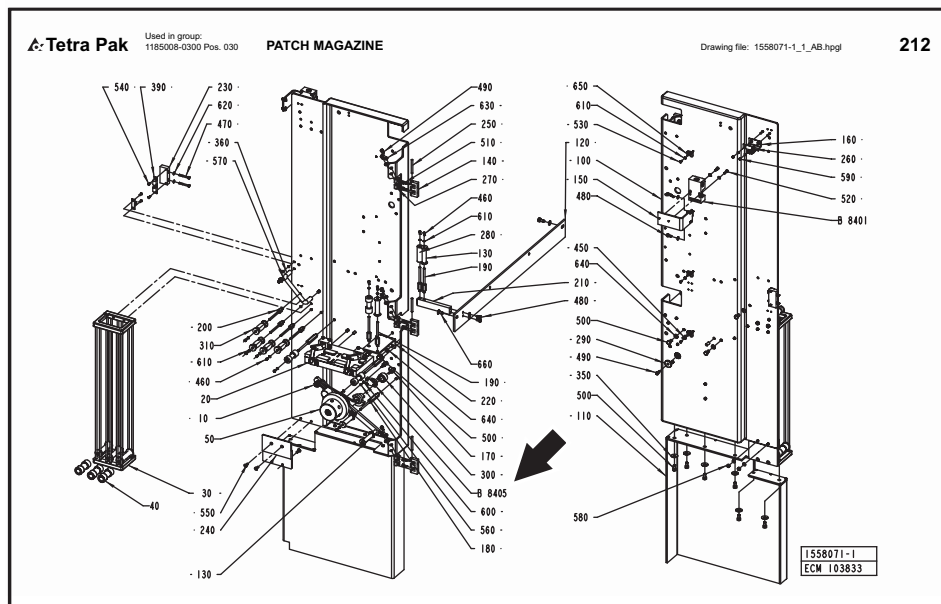

Pos	Part No	SP	UN	Qty	Description	Page No	Pos	Part No	SP	UN	Qty	Description	Page No
010	A1496265-0100	-	1	1	DETECTOR	197	580	312905-0310	-	2	2	HEXAGON NUT, M6X M3 A280	
020	A1496260-0100	-	1	1	SPLICING TABLE	215	580	312912-0312	-	2	2	HEXAGON NUT, NY-LOCK M6 A480	
030	A1519708-0100	-	1	1	MAGAZINE	219	580	312912-0312	-	2	2	HEXAGON NUT, M6X M6 A280	
040	A1549260-0100	-	1	1	PATCH MAGAZINE	221	600	315105-0124	-	2	2	WASHER PLAIN, B.BB, 3,26, H=0,5	
050	A1558113-0100	-	1	1	BUBBIN HOLDER	223	610	315105-0136	-	19	19	WASHER PLAIN, B.BB, 4,38, H=0,8	
100	1539208-0000	-	1	1	FLATE	620	620	315105-0146	-	4	4	WASHER PLAIN, B.BB, 5,310, H=1	
110	1558111-0000	-	1	1	PROTECTION	630	630	315105-0153	-	14	14	WASHER PLAIN, B.BB, 6,412, H=1,5	
120	1519714-0000	-	1	1	SUPPORT	640	640	315105-0165	-	7	7	WASHER PLAIN, B.BB, 8,416, H=1,5	
130	905211-0000	A	3	3	ROLLER	650	650	352113-0204	-	4	4	ANCHOR PLATES FOR STRIPS, TYPE TMS25-M	
140	1035752-0000	-	3	3	HINGE	660	660	312155-0449	-	1	1	SCREW EM 10642 MFS M6X16 A480	
150	1082741-0000	-	1	1	HOLDER	B8401	B8401	90044-0139	A	1	1	KEY SAF.SW. AZ16-02 ZVR K-2254	
160	1129042-0000	-	1	1	KEY	B8405	B8405	90044-0194	A	1	1	PROX.SW. IN5329/IN3002-BPKG	
170	1496250-0000	-	2	2	AXLE PIN								
180	1496251-0002	-	3	3	AXLE PIN								
190	1496251-0003	-	4	4	AXLE PIN								
200	1496251-0005	-	4	4	AXLE PIN								
210	1519716-0000	-	1	1	SUPPORT								
220	1539225-0000	-	1	1	BRACKET								
230	1549232-0000	-	1	1	BLOCK								
240	2501191-0000	-	1	1	PLATE								
250	696265-0000	-	3	3	PIN								
260	1036563-0000	-	1	1	WASHER								
270	1129770-0000	-	6	6	BLOCKING PRECE								
280	1140727-0000	A	1	1	ROLLER								
290	1498347-0000	-	1	1	WASHER								
300	1496253-0000	-	1	1	BUSHING								
310	2501195-0000	A	4	4	ROLLER								
360	90005-0105	-	6	6	WASHER PLAIN ROUND 8,44(M)24, H=1,5								
360	90017-0016	-	1	1	HANDLE, NO. 14.4012.02.120								
390	90237-0070	-	1	1	SNAP-IN BALL LOCK 60X19 MM								
450	311103-0401	-	2	2	PARALLEL PIN, I.BK, 8200 MM								
460	312105-0287	-	11	11	SCREW MISS ISO 4017 M6X8 A480								
470	312105-0339	-	2	2	SCREW MISS ISO 4014 M6X10 A480								
480	312105-0366	-	4	4	SCREW MISS M6X12 A280								
490	312105-0368	-	9	9	SCREW MISS M6X16 A280								
500	312105-0449	-	13	13	SCREW MISS ISO 4017 M6X16 A480								
510	312115-0327	-	6	6	SCREW MISS M6X12 A280								
520	312115-0329	-	2	2	SCREW MISS M6X16 A280								
530	312122-0287	-	4	4	SCREW PAN HEAD M6S M4X0,5S								
540	312155-0291	-	4	4	SCREW EN 10642 MFS M6X12 A480								
550	312155-0368	-	4	4	SCREW EN 10642 MFS M6X16 A480								

TechPub\_2614345\_0105 - EM\_2890021\_0101.int.fm

# ii Safety Precautions

TechPub\_2614345\_0105 - EM\_2890021\_0101.sp.fm

## Safety Precaution Instructions



### **WARNING**

**Read all safety precaution instructions throughout this manual and on safety signs attached to this equipment.**

Failure to follow all safety precaution instructions could result in death or serious injury.

## Definition of Lockout Procedure

A lockout procedure is a procedure to put each necessary energy isolating device in its safe position to prevent the energisation of the equipment, such as when a maintenance procedure should be carried out.

A lockout is the use of a device, for example, a padlock, to make sure that an energy isolating device cannot be operated.

An energy isolating device is a mechanical device that physically prevents transmission or release of energy, such as a power supply disconnecter.

<b>Safety Messages Description</b> . . . . .	<b>ii - 5</b>
<b>Personnel Requirements</b> . . . . .	<b>ii - 6</b>
<b>Skilled Person</b> . . . . .	<b>ii - 6</b>
<b>Instructed Person</b> . . . . .	<b>ii - 6</b>
<b>Safety Signs</b> . . . . .	<b>ii - 7</b>
<b>Locations of Safety Signs</b> . . . . .	<b>ii - 8</b>
<b>Protective Devices</b> . . . . .	<b>ii - 9</b>
<b>Emergency Stop</b> . . . . .	<b>ii - 9</b>
<b>Emergency Stop Push-Buttons</b> . . . . .	<b>ii - 10</b>
<b>Safeguards</b> . . . . .	<b>ii - 11</b>
<b>Warning Lamp</b> . . . . .	<b>ii - 12</b>
<b>Personal Protection</b> . . . . .	<b>ii - 13</b>
<b>Noise Hazard</b> . . . . .	<b>ii - 13</b>
<b>Entanglement Hazard</b> . . . . .	<b>ii - 13</b>
<b>Hazardous Substances</b> . . . . .	<b>ii - 14</b>
<b>Disposal of Chemical Substances</b> . . . . .	<b>ii - 15</b>
<b>Hydrogen Peroxide (H<sub>2</sub>O<sub>2</sub>)</b> . . . . .	<b>ii - 16</b>
<b>Emergency Procedures</b> . . . . .	<b>ii - 16</b>
<b>Personal Protective Equipment</b> . . . . .	<b>ii - 17</b>
<b>Handling of Hydrogen Peroxide</b> . . . . .	<b>ii - 18</b>
<b>Storage of Hydrogen Peroxide</b> . . . . .	<b>ii - 19</b>
<b>Disposal of Hydrogen Peroxide</b> . . . . .	<b>ii - 20</b>
<b>Supply Systems</b> . . . . .	<b>ii - 21</b>
<b>Power Supply</b> . . . . .	<b>ii - 21</b>
<b>Electrical Cabinet</b> . . . . .	<b>ii - 22</b>
<b>Air Supply</b> . . . . .	<b>ii - 23</b>
<b>Steam Supply</b> . . . . .	<b>ii - 24</b>
<b>Water Supply</b> . . . . .	<b>ii - 25</b>

This page intentionally left blank



TechPub\_2614345\_0105 - EM\_2890021\_0101.sp.fm

## Safety Messages Description

A safety message is always accompanied by a safety alert symbol and a signal word.

The safety alert symbol is used to alert about potential personal injury hazards. To avoid hazards, obey all safety messages that follow this symbol.

The following safety alert symbols and signal words are used in this manual to inform the user of hazards.

 <b>DANGER</b>	Danger indicates an imminently hazardous situation which, if not avoided, will result in death or serious injury.
 <b>WARNING</b>	Warning indicates a potentially hazardous situation which, if not avoided, <b>could</b> result in <b>death or serious injury</b> .
 <b>CAUTION</b>	Caution indicates a potentially hazardous situation which, if not avoided, <b>may</b> result in <b>minor or moderate injury</b> . It may also be used to alert against unsafe practices.
<b>CAUTION</b>	Caution without the safety alert symbol indicates a potentially hazardous situation which, if not avoided, <b>may</b> result in <b>property damage</b> .

## Personnel Requirements

**Note!** Personnel includes all persons working on or near this equipment.

Only skilled or instructed persons are allowed to work with this equipment.

### Skilled Person

A skilled person must have relevant education and experience to enable him or her to identify hazards, analyse risks, and avoid hazards which electricity, machinery, chemicals, other energies, and supply systems on this equipment can create.

Skilled persons must meet local regulations, such as certifications and qualifications for working with these energies and systems.

### Instructed Person

An instructed person must be adequately advised or supervised by a skilled person. The skilled person enables the instructed person to identify hazards, analyse risks, and avoid hazards which electricity, machinery, chemicals, other energies, and supply systems on this equipment can create.

# Safety Signs



**! WARNING**

**Damaged or missing safety signs increase the risk of death or serious injury.**

Replace all missing or damaged safety signs immediately.

Safety signs are attached to the equipment.

- Make sure that each safety sign is legible and in its correct position after installation and maintenance.
- Replace all missing or damaged safety signs immediately.

Pos.	ISO sign	ANSI sign
1	 <p><b>Hazardous voltage.</b> Will shock, burn, or cause death. Follow lockout procedure before maintenance.</p>	

TechPub\_2614345\_0105 - EM\_2890021\_0101.sp.fm

### Locations of Safety Signs

The illustration shows where the safety signs are located. The position numbers refer to the table in the Safety Signs section.

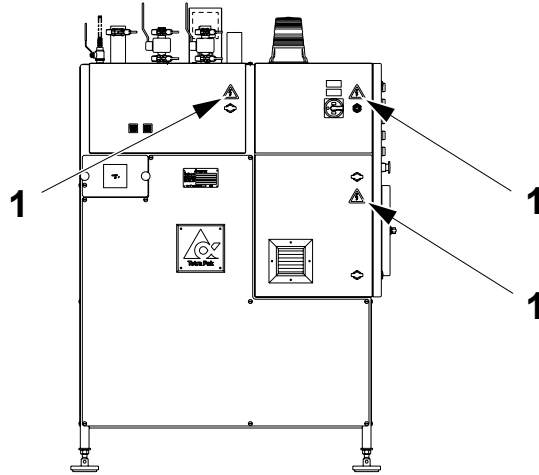

LH side

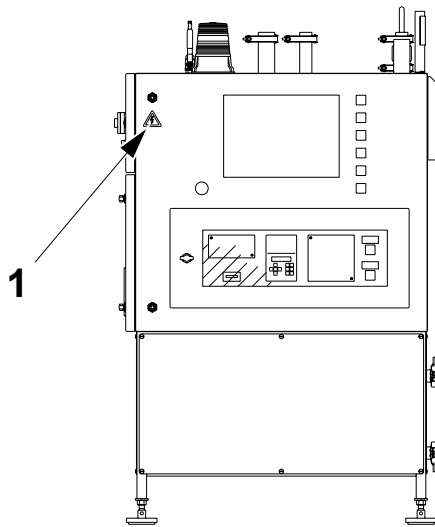

Front side

## Protective Devices



### WARNING

#### **Hazardous zones.**

Hazardous zones are safeguarded and provided with protective devices. Do not touch or run this equipment if any protective device is inoperative.

Change inoperative components of the safety system immediately.



### WARNING

#### **Hazardous voltage.**

Hazardous voltage remains on this equipment after activating an EMERGENCY STOP or an interlocking device.

## Emergency Stop

Emergency stop devices are used to stop this equipment immediately in a hazardous situation. Learn the positions of all emergency stop devices and how to use them.

Instructions for a normal production stop are included in the Stop chapter of the Operation Manual.

### Emergency Stop Push-Buttons

Push one of the EMERGENCY STOP push-buttons to stop this equipment immediately.

The location of each EMERGENCY STOP push-button is shown by an arrow.

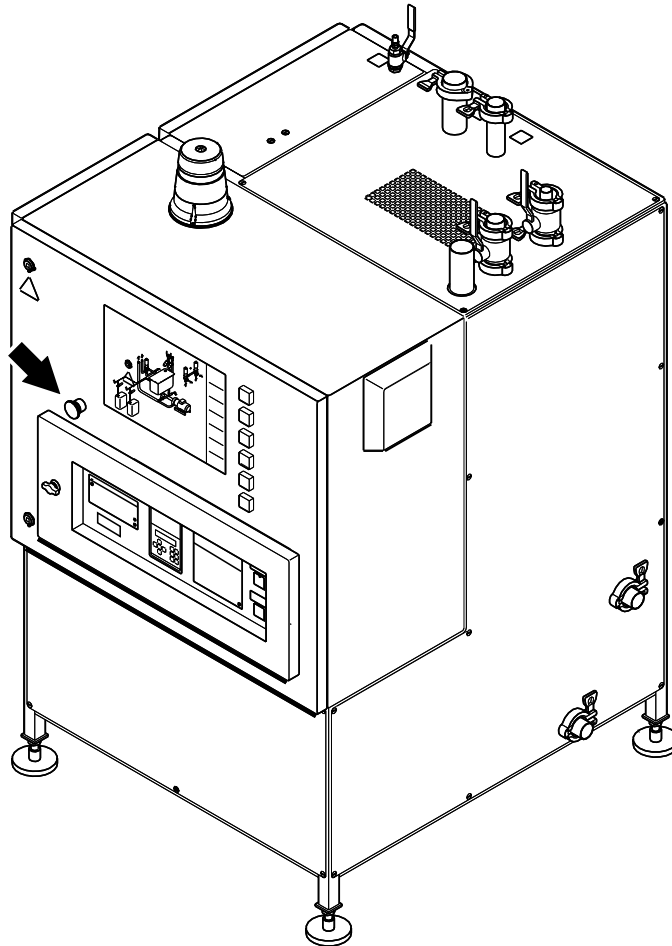
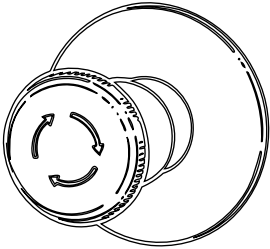

## Safeguards



### WARNING

#### Moving machinery.

Never defeat or bypass the interlocking devices.

Movable guards, for example, doors and covers leading to hazardous zones, are fitted with interlocking devices where required. These devices are usually electric safety switches that are parts of the safety system and must never be defeated, bypassed, or otherwise made inoperative.



### CAUTION

#### Burn hazard.

Parts of this equipment may be hot after operation.

After installation and maintenance, and before this equipment is inched or run, check that all safeguards are in place and that they operate correctly.

### CAUTION

#### Equipment damage.

Never stop this equipment by opening an interlocking guard.

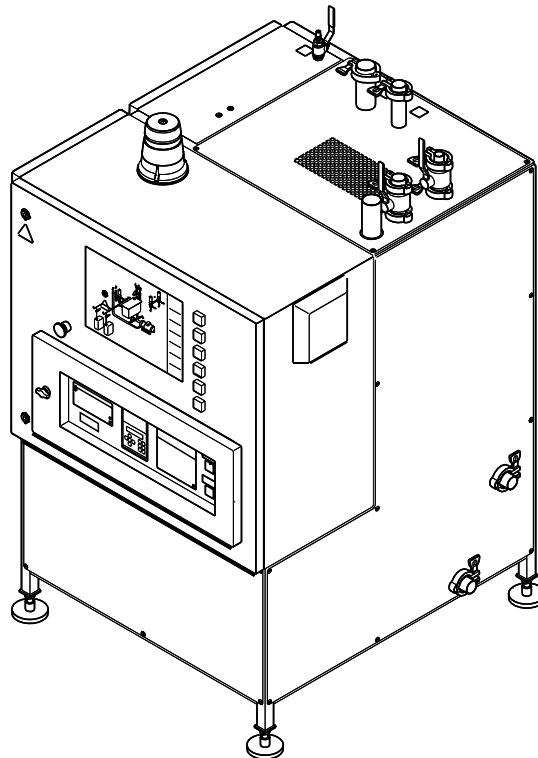

## Warning Lamp

A warning light flashes when operator action is required. The light stops flashing and remains lit when the alarm is acknowledged. After the fault is corrected, the operator takes the appropriate action or the machine is reset, the warning light goes off.

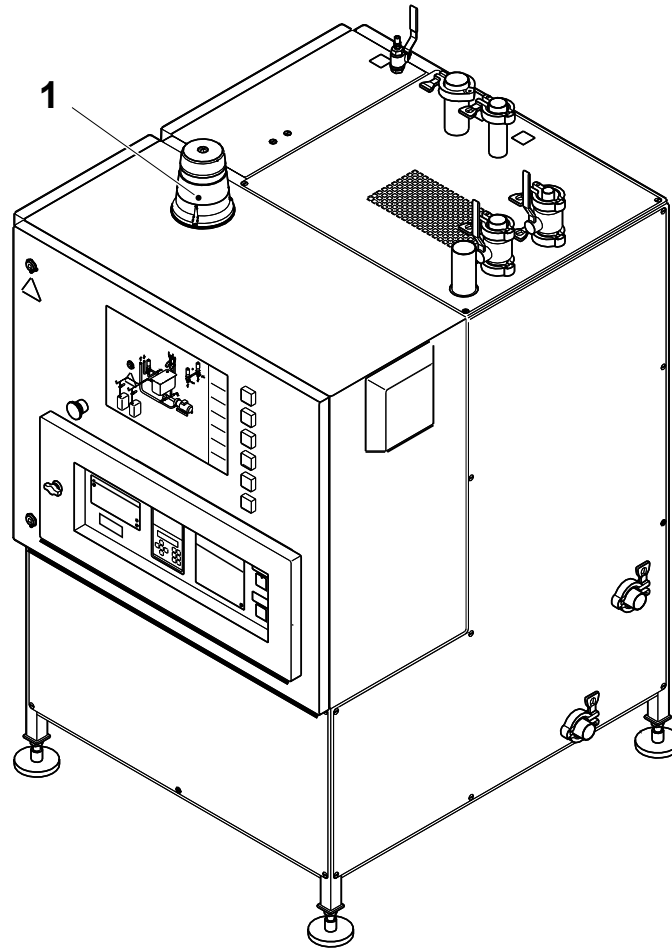

1 Warning lamp

## Personal Protection

This section applies to all personnel at all times when this equipment is in operation. For special personal protection required when handling hazardous substances, see the Hazardous Substances section.

### Noise Hazard



#### **CAUTION**

##### **Hazardous noise.**

Risk of impaired hearing. Hearing protection is recommended whenever this equipment is in operation.

### Entanglement Hazard



#### **WARNING**

##### **Risk of entanglement.**

Do not wear jewellery or loose clothing when working on or near this equipment. Long hair may not be loose.

## Hazardous Substances

### WARNING

**Contact with chemicals can cause death, serious injury, or illness.**

Always read and follow the instructions in the safety data sheet supplied by the manufacturer or local supplier, when handling chemicals.

Make sure that

- the safety data sheet is available
- the showers work
- an eyewash device, movable or wall-mounted, is available and operational
- additional washing facilities are nearby

**Note!** Learn the locations of all washing facilities in order to act immediately in case of an accident



## Disposal of Chemical Substances

Always read and follow the disposal instructions in the safety data sheet supplied by the manufacturer or local supplier.

It is strongly recommended that used chemical containers are

- disposed of according to the instructions immediately after use
- not used as disposal containers for other chemicals in order to avoid uncontrolled chemical reactions within the container

## Hydrogen Peroxide (H<sub>2</sub>O<sub>2</sub>)



### WARNING

#### Corrosive chemical.

Wear personal protective equipment.

In both liquid and gas states, hydrogen peroxide may cause irritation or damage if it comes into contact with skin, mucous membranes, eyes, or clothes. Call for medical attention immediately if there is an accident.

Liquid hydrogen peroxide in concentrations of less than 1% is generally considered harmless to humans.

Consult the instructions on the label of the tank or container.

### Emergency Procedures

If there is an accident involving hydrogen peroxide, rinse the affected area as soon as possible with large amounts of water.

If hydrogen peroxide is swallowed

- do not attempt to cause vomiting
- drink large amounts of lukewarm water to dilute the peroxide
- call for medical attention immediately

If splashes or vapour from hydrogen peroxide come in contact with the eyes

- wash the eyes thoroughly with lukewarm water for 15 minutes (keep eyelids wide apart)
- call for medical attention immediately

If hydrogen peroxide comes into contact with skin or clothes

- rinse immediately with plenty of water
- call for medical attention immediately if skin burns appear
- thoroughly wash the clothes before wearing them again

If irritation or pain is experienced due to having **inhaled** hydrogen peroxide vapour

- leave the affected area and get some fresh air
- call for medical attention if the symptoms get worse

### Personal Protective Equipment

The personal protective equipment for hydrogen peroxide is

- protective goggles (TP No. 90303-11)
- protective gloves made of neoprene (TP No. 90303-12)
- protective apron (TP No. 90303-13)
- protective shoes made of PVC, PE plastic, or rubber

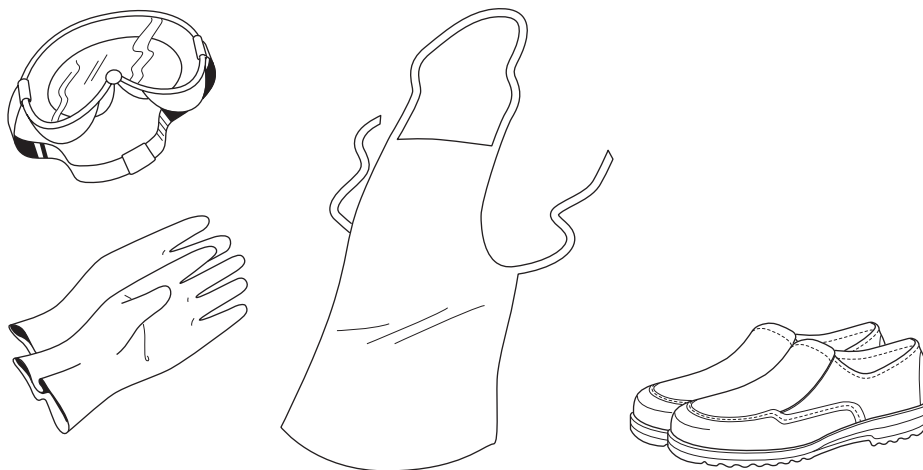

## Handling of Hydrogen Peroxide

### **WARNING**

#### **Sudden and violent chemical reaction.**

Avoid any contamination of hydrogen peroxide.

Hydrogen peroxide reacts suddenly and violently with many compounds or if it is contaminated. The reaction is a violent decomposition liberating oxygen and heat, with a big increase in volume due to the oxygen produced by the peroxide decomposition.

Never pour surplus hydrogen peroxide back into the original container if it contains fresh hydrogen peroxide. There is a risk of explosion when hydrogen peroxide is in a closed container.

Ensure that equipment used for handling and diluting hydrogen peroxide is clean before it comes in contact with hydrogen peroxide. Pumps or other equipment used for handling hydrogen peroxide must be **used for this purpose only** and must be manufactured from appropriate materials, such as stainless steel 316 L, glass, polyethylene, or teflon. After use, make sure that all peroxide residue is rinsed away.

If hydrogen peroxide is spilled, dilute it with large amounts of water. Dispose of the diluted hydrogen peroxide according to local regulations.

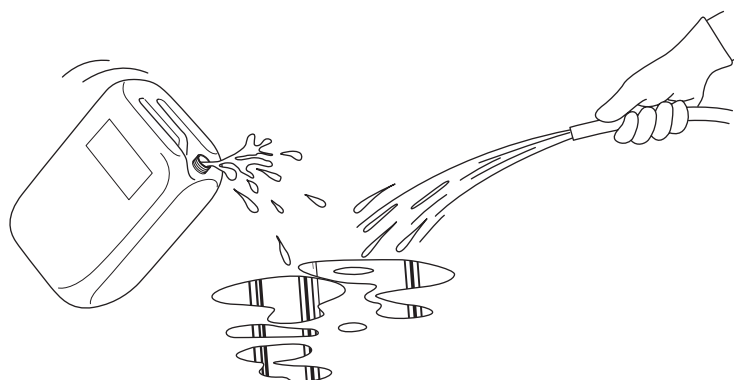

### **WARNING**

#### **Self-ignition.**

Never wipe up hydrogen peroxide with materials such as rags or paper as these may self-ignite several hours after contact. If there is a fire, spray with large quantities of water.

## Storage of Hydrogen Peroxide



**Containers may explode if not properly ventilated.**

Keep the container upright and fitted with its proper ventilation cap. If there is a fire, cool all containers by spraying them with large quantities of water.

Hydrogen peroxide decomposes much faster with increasing temperature. There is a risk of explosion at high temperatures, since the ventilation cap cannot release the gases produced quickly enough.

Hydrogen peroxide **must** be stored in the **original container** delivered by the supplier. Keep the container upright and fitted with its proper ventilation cap, which allows oxygen to escape. Otherwise, there can be an explosion if decomposition of the peroxide occurs violently.

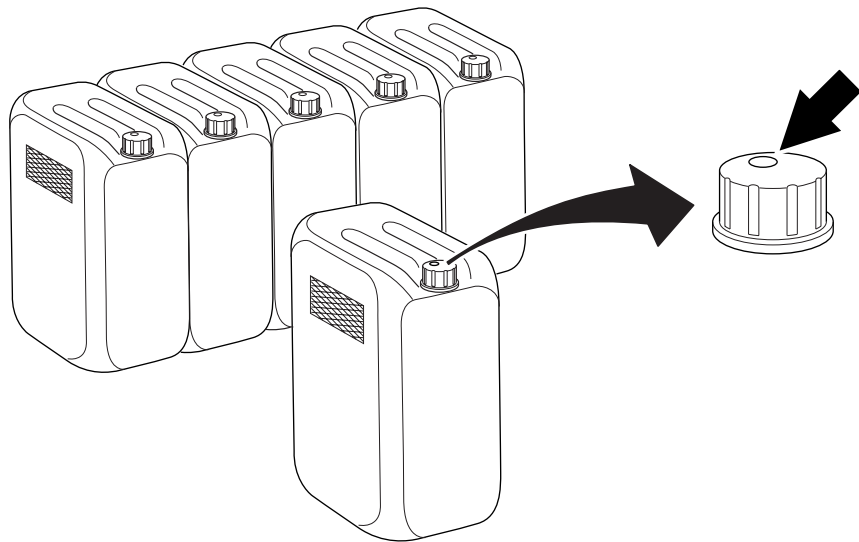

Make sure that the container is always properly closed.

*(Cont'd)*

(Cont'd)

Commercial food-grade hydrogen peroxide has been stabilized to inhibit the catalytic decomposition effects of metals and other impurities, but it can decompose into oxygen and water if it is exposed to heat or contaminated.

Make sure that the area used for storage of hydrogen peroxide is

- cool, clean, and well ventilated
- shielded from direct sunlight
- kept free from combustible materials

### Disposal of Hydrogen Peroxide

Always read and follow the disposal instructions in the safety data sheet supplied by the manufacturer or local supplier.

# Supply Systems

## Power Supply



### **Hazardous voltage and moving machinery.**

The power supply disconnecter must be turned off and secured with a lock before any maintenance.

**Note!** The key to the lock must be removed by the technician and retained in his/her possession until all work is completed.

Certain maintenance procedures may require power supply systems to be on. These exceptions are clearly stated in the Maintenance Manual.

The illustrations show the power supply disconnecter and its location.

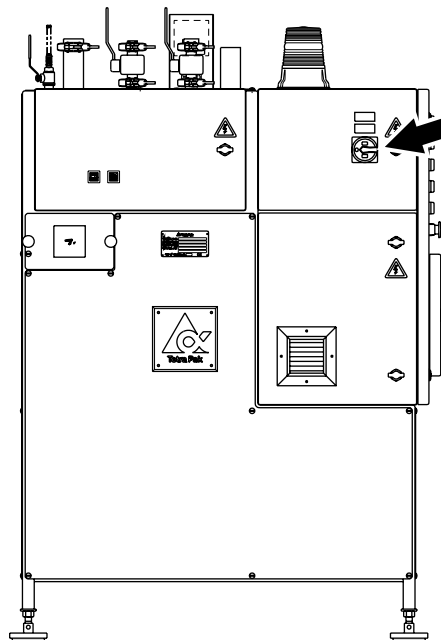

## Electrical Cabinet



**Hazardous voltage.**

Will shock, burn, or cause death. The power supply disconnecter must be turned off and secured with a lock before maintenance inside the electrical cabinet.

**Note!** The key to the lock must be removed by the technician and retained in his/her possession until all work is completed.

Make sure that the electrical cabinet doors are closed after working inside the electrical cabinet. Doors with lock must be locked.

## Air Supply

### **WARNING**

#### **Compressed air and moving machinery.**

Close the main air valve and lock it before any maintenance.

**Note!** The key to the lock must be removed by the technician and retained in his/her possession until all work is completed.

Certain maintenance procedures may require air supply systems to be on. These exceptions are clearly stated in the Maintenance Manual.

The illustrations show the air supply valve and its location.

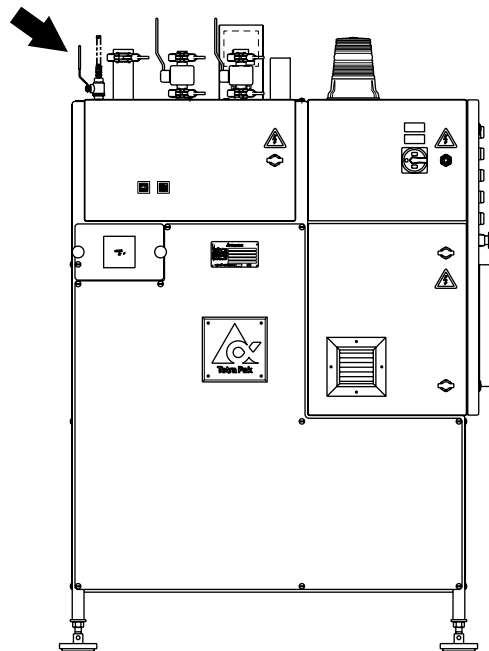

## Steam Supply

### **WARNING**

#### **Hot steam can cause scalds.**

Pressurized steam can be discharged unexpectedly. Close the steam supply valve and lock it, depressurize and vent all steam safely before any maintenance on parts with steam, such as pipes and valves.

**Note!** The key to the lock must be removed by the technician and retained in his/her possession until all work is completed.

Certain maintenance procedures may require steam supply systems to be on. These exceptions are clearly stated in the Maintenance Manual.

The illustrations show the steam supply valve (1), and its location.

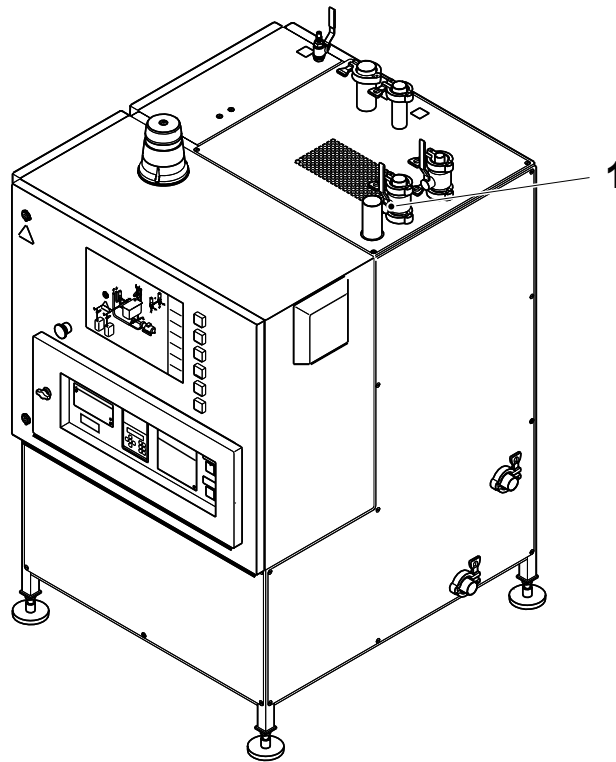

1 Steam supply valve

## Water Supply

### CAUTION

#### **Water under pressure.**

Close the water supply valves before any maintenance.

Certain maintenance procedures may require water supply systems to be on. These exceptions are clearly stated in the Maintenance Manual.

The illustrations show the water supply valves (1), and their location.

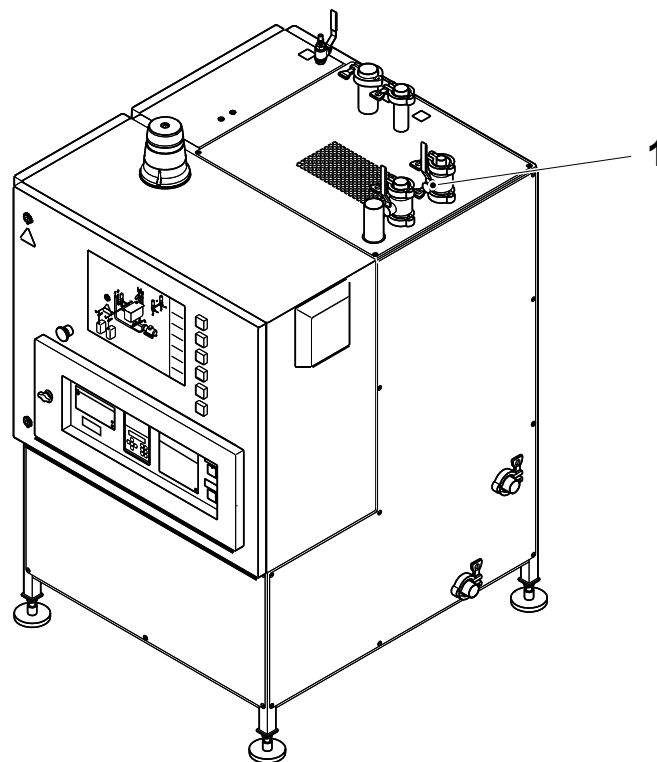

1 Water supply valve

This page intentionally left blank

TechPub\_2614345\_0105 - EM\_2890021\_0101.sp.fm

# 1 Electrical Systems Description

TechPub\_2614345\_v3\_DRAFT\_Release01\_EM2890021\_01.en.fm

## Description

This chapter contains a description of the electrical system in the machine or equipment.

**1.1 Electrical System Description . . . . . 1 - 5**

**1.2 Safety System . . . . . 1 - 6**

Safety System - Circuit . . . . . 1 - 6

TechPub\_2614345\_v3\_DRAFT\_Release01\_EM2890021\_01.en.fm

This page intentionally left blank

TechPub\_2614345\_v3\_DRAFT\_Release01\_EM2890021\_01.en.fm

# 1.1 Electrical System Description

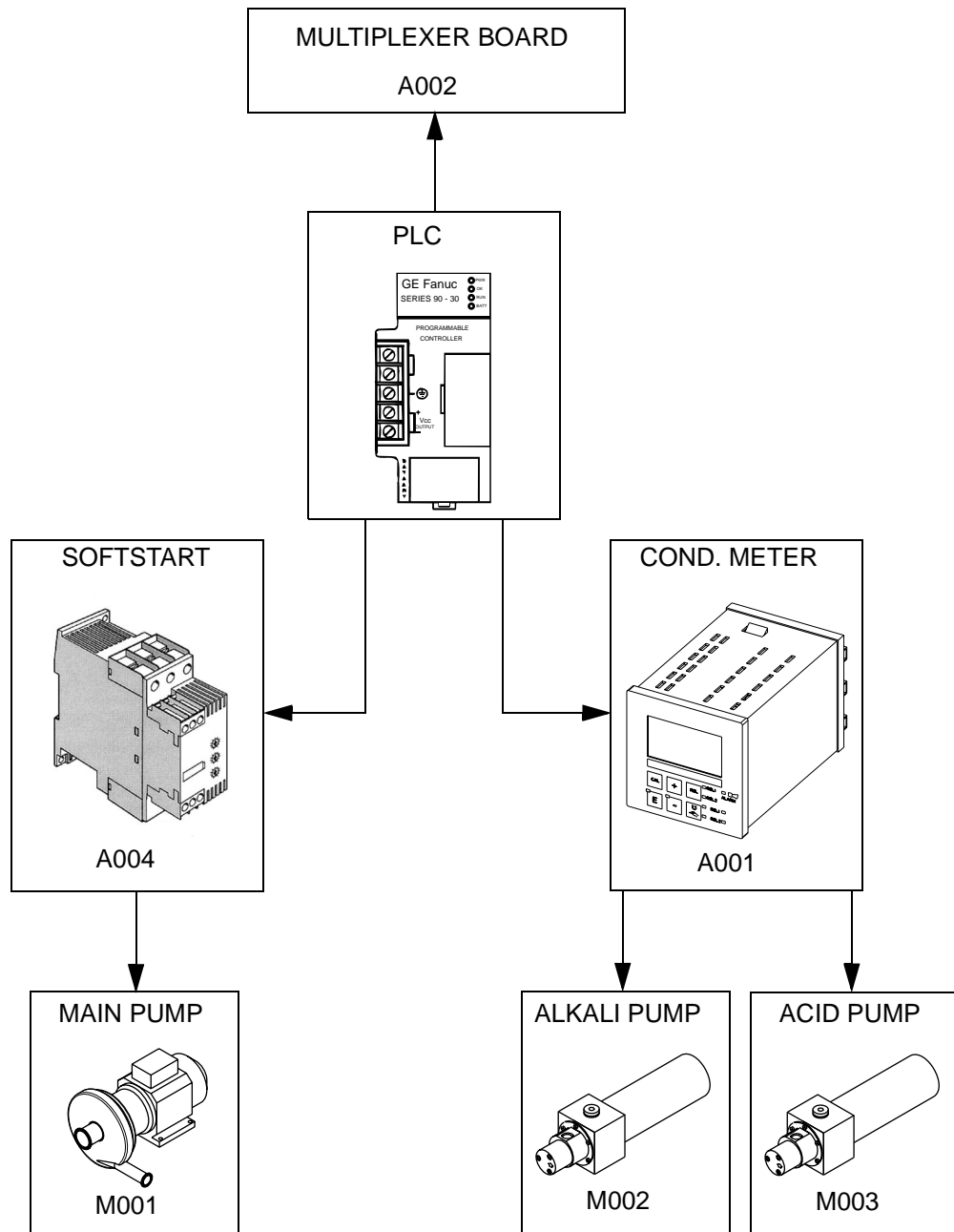

TechPub\_2614345\_v3\_DRAFT\_Release01\_EM2890021\_01en.fm

# 1.2 Safety System

## Safety System - Circuit

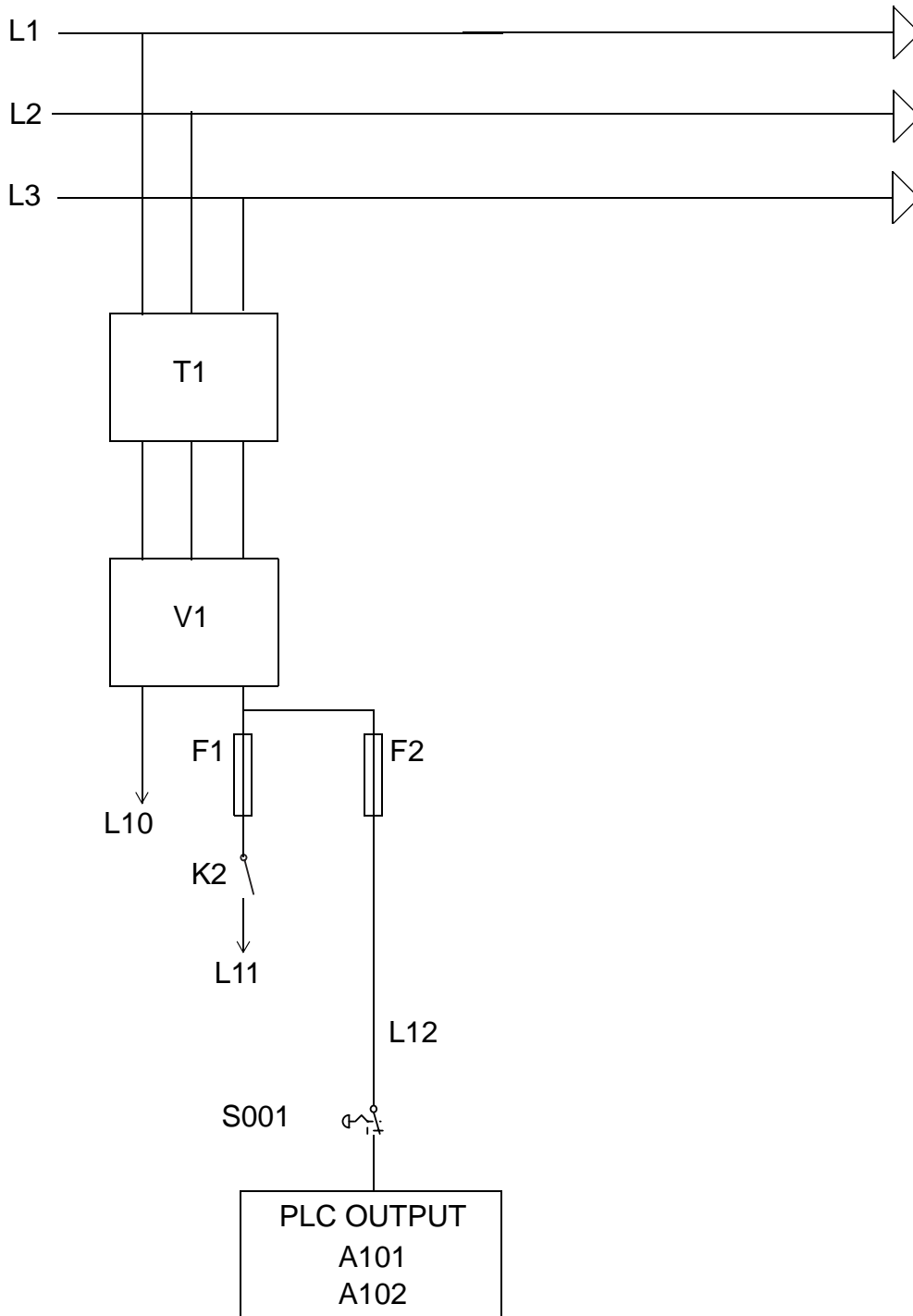

TechPub\_2614345\_v3\_DRAFT\_Release01\_EM2890021\_01.en.fm

# 2 Document List

TechPub\_2614345\_v3\_DRAFT\_Release02\_EM2890021\_01.en.fm

### Description

This chapter is a table of contents that includes the drawing specification for each electrical document valid for the equipment



---

This page intentionally left blank

# 3 Position Summary

### Description

This chapter is a list of all electrical components that are shown in the electrical drawings, with page references to the drawings where they are located.

Position summary of 2895133-0003

Component	Page .Col.	Opt.
+C-A001	010.4	
+C-A002	18.2	
+C-A003	18.5	
+C-A004	006.3	
+C-A005	28.4	
+C-A015	011.7	FLOW
+C-A100	007.6	
+C-A101	25.1	
+C-A102	27.1	
+C-A110	37.7	
+C-A111	39.7	
+C-A112	41.7	
+C-A113	43.8	
+M-B001	010.4	
+M-B002	39.4	
+M-B003	39.4	
+M-B004	39.4	
+M-B005	39.4	
+M-B007	40.5	
+M-B008	40.5	
+M-B010	40.5	2_MACH
+M-B011	40.5	2_MACH
+M-B015	011.3	FLOW
+C-F001	007.2	
+C-F002	007.2	
+C-F003	007.5	
+C-F004	007.6	
+C-G100	007.6	

Component	Page .Col.	Opt.
+C-H001	18.5	
+M-H001S	27.4	
+C-H002S	28.4	
+M-H002S	27.4	
+C-H003S	28.4	
+C-H004S	28.4	
+C-H005S	28.4	
+C-H010	18.5	
+C-H011	18.5	
+C-H012	18.5	
+C-H013	18.5	
+C-H014	18.5	
+C-H015	18.5	
+C-H016	18.5	
+C-H017	18.5	
+C-H018	19.5	
+C-H019	19.5	
+C-H020	19.5	
+C-H021	19.5	
+C-H022	19.5	
+C-H023	19.5	
+C-H024	19.5	
+C-H025	19.5	
+C-H026	19.5	
+C-H027	19.5	
+C-H028	20.5	
+C-H029	20.5	
+C-H030	20.5	

Component	Page .Col.	Opt.
+C-H031	20.5	
+C-H032	20.5	
+C-H033	20.5	
+C-H034	20.5	
+C-H035	20.5	
+C-H036	20.5	
+C-K001	25.5	
+C-K002	25.5	
+C-K003	25.5	
+C-K004	25.5	
+C-K005	25.5	
+C-K006	25.5	
+C-K008	25.5	
+C-K009	26.5	
+C-K010	26.5	
+C-K014	25.5	
+C-M001	009.5	
+M-M001	006.3	
+M-M002	008.2	
+M-M003	008.4	
+C-P001	12.4	REC.
+C-P002	28.4	
+C-Q001	005.2	
+C-Q002	005.8	
+C-Q003	006.3	
+C-Q005	007.2	
+C-R001	12.3	
+C-R002	12.3	

Component	Page .Col.	Opt.
+C-R003	12.3	
+C-S001	37.4	
+M-S001H	41.4	
+C-S002H	37.4	
+M-S002H	41.4	
+C-S003H	37.4	
+C-S004H	37.4	
+C-S005H	37.4	
+C-S006	37.4	
+C-S007	37.4	
+C-S008	38.4	
+C-S009	38.4	
+C-T001	007.1	
+C-V001	007.2	
+M-Y001	26.5	
+M-Y002	26.5	
+M-Y003	26.5	
+M-Y004	26.5	
+M-Y005	26.5	
+M-Y006	26.5	
+C-Z001	005.6	
+C-Z002	005.6	
+C-Z003	010.4	

		Designer LUP ECM No 303930	Date 25/05/2007 Denomination POSITION SUMMARY	Machine SCUJ4-0150 Page Type POSITION SUMMARY	Doc. type ELD	Version AA	Page 001
Company Tetra Pak (Italy)							
Drawing remarks							
Document No. 2895133-0002							

---

This page intentionally left blank

# 4 Circuit Diagrams

TechPub\_2614345\_v3\_DRAFT\_Release04\_EM2890021\_01.en.fm

### Description

This chapter contains all component drawings, such as programmable logic controller (PLC) modules, terminals, and cables.

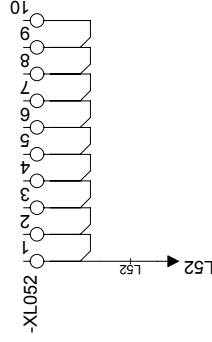
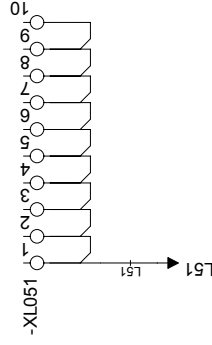
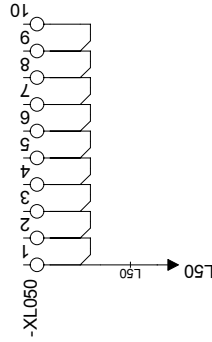
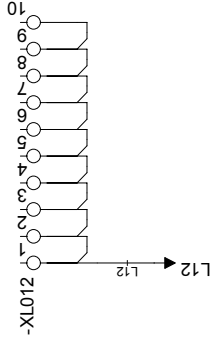
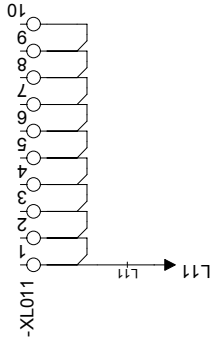
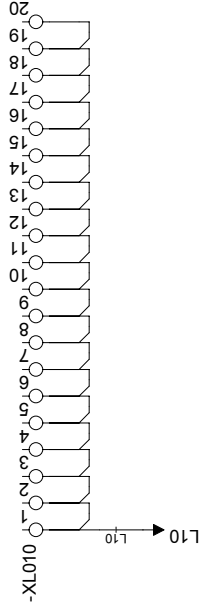

<b>Tetra Pak</b>		Designer LUP	Date 25/05/2007	Machine SCU/4-0150
Company Tetra Pak (Italy)		ECM No 303930	Denomination CIRCUIT DIAGRAM	Page Type DISTRIBUTION TERMINALS
Drawing remarks		Document No. 2895133-0003		Doc. type ELD
				Version AA
				Page 001

1 2 3 4 5 6 7 8 9 10

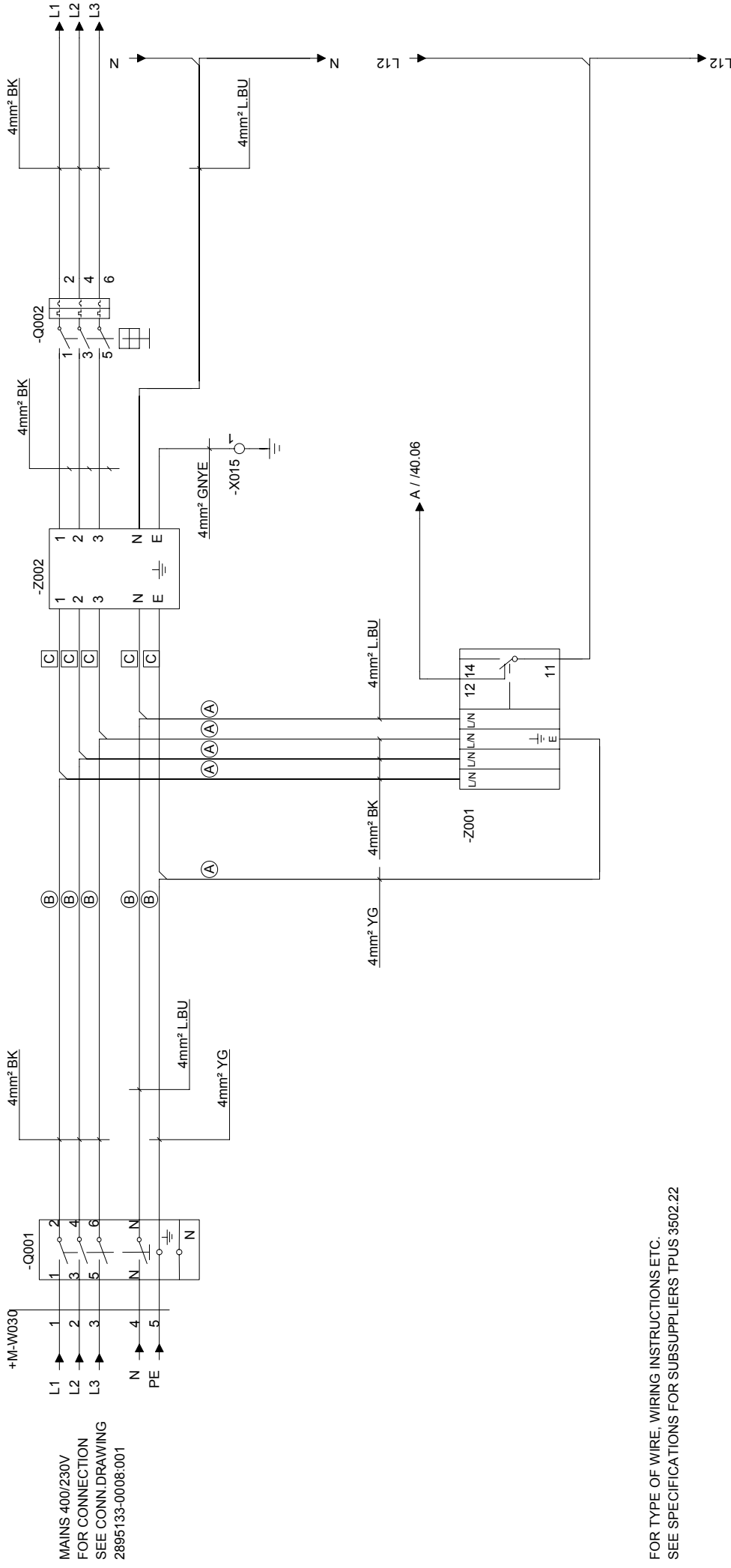

MAINS 400/230V  
 FOR CONNECTION  
 SEE CONN.DRAWING  
 2895133-0008:001

FOR TYPE OF WIRE, WIRING INSTRUCTIONS ETC.  
 SEE SPECIFICATIONS FOR SUBSUPPLIERS TPUS 3502.22

WHERE NOTHING ELSE IS SAID  
 OR LINE SUMMARY IS VALID: 0.75 mm² BU

		Designer LUP ECM No 303930	Date 25/05/2007 Denomination <b>CIRCUIT DIAGRAM</b>	Machine SCUJ4-0150 Page Type <b>MAINS</b>	Doc. type <b>ELD</b>	Version <b>AA</b>	Page <b>005</b>
Company <b>Tetra Pak (Italy)</b>		Document No. <b>2895133-0003</b>		Drawing remarks			

RELEASED

This drawing must not, without the consent of Tetra Pak, be copied, transmitted or disclosed to any third party.

1	2	3	4	5	6	7	8	9	10
---	---	---	---	---	---	---	---	---	----

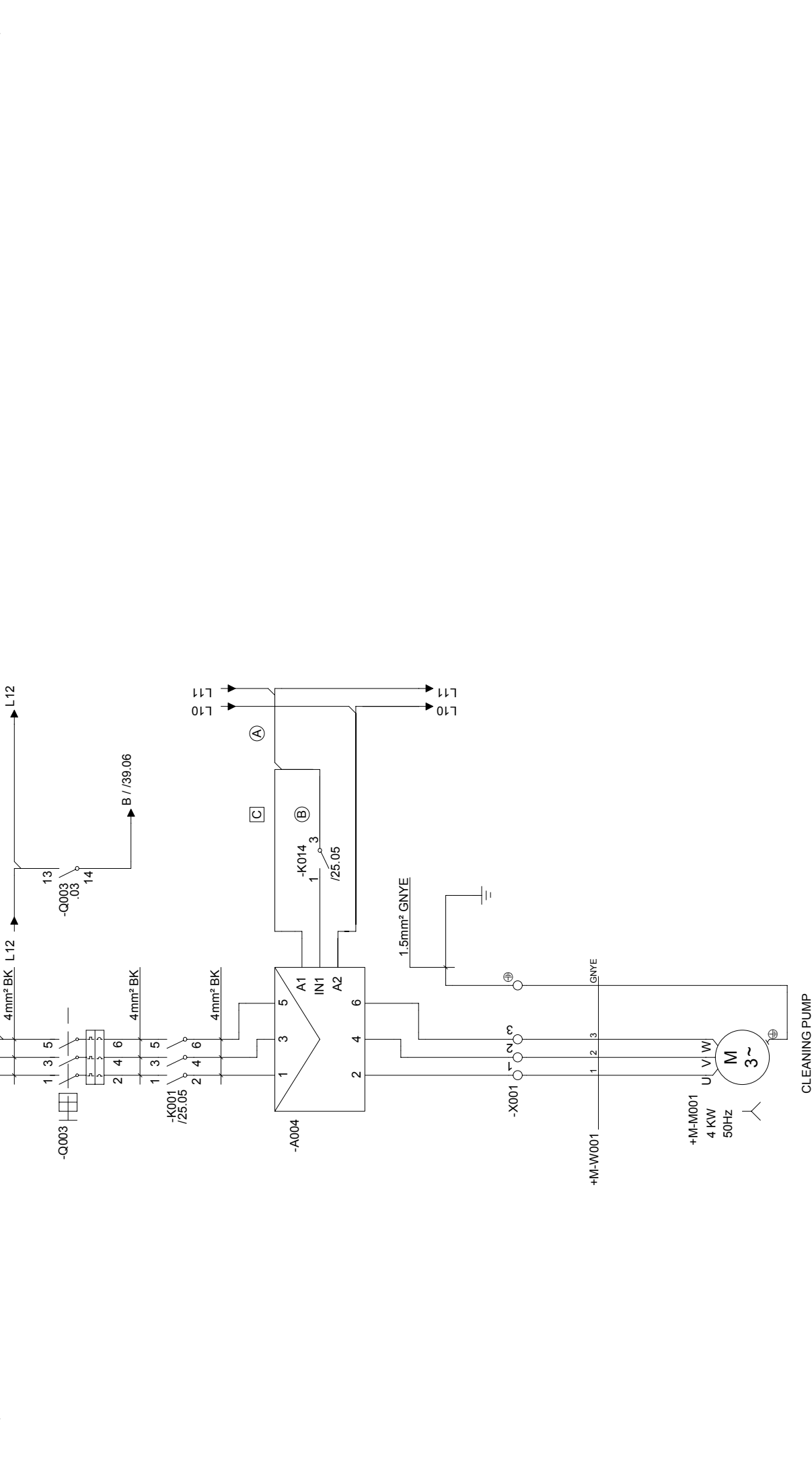

CLEANING PUMP

		Designer LUP ECM No 303930	Date 25/05/2007	Machine SCUJ4-0150
		Denomination <b>CIRCUIT DIAGRAM</b>		
		Page Type <b>MOTOR</b>		
Company <b>Tetra Pak (Italy)</b>		Document No. <b>2895133-0003</b>	Doc. type <b>ELD</b>	Version <b>AA</b>
Drawing remarks		Page <b>006</b>		

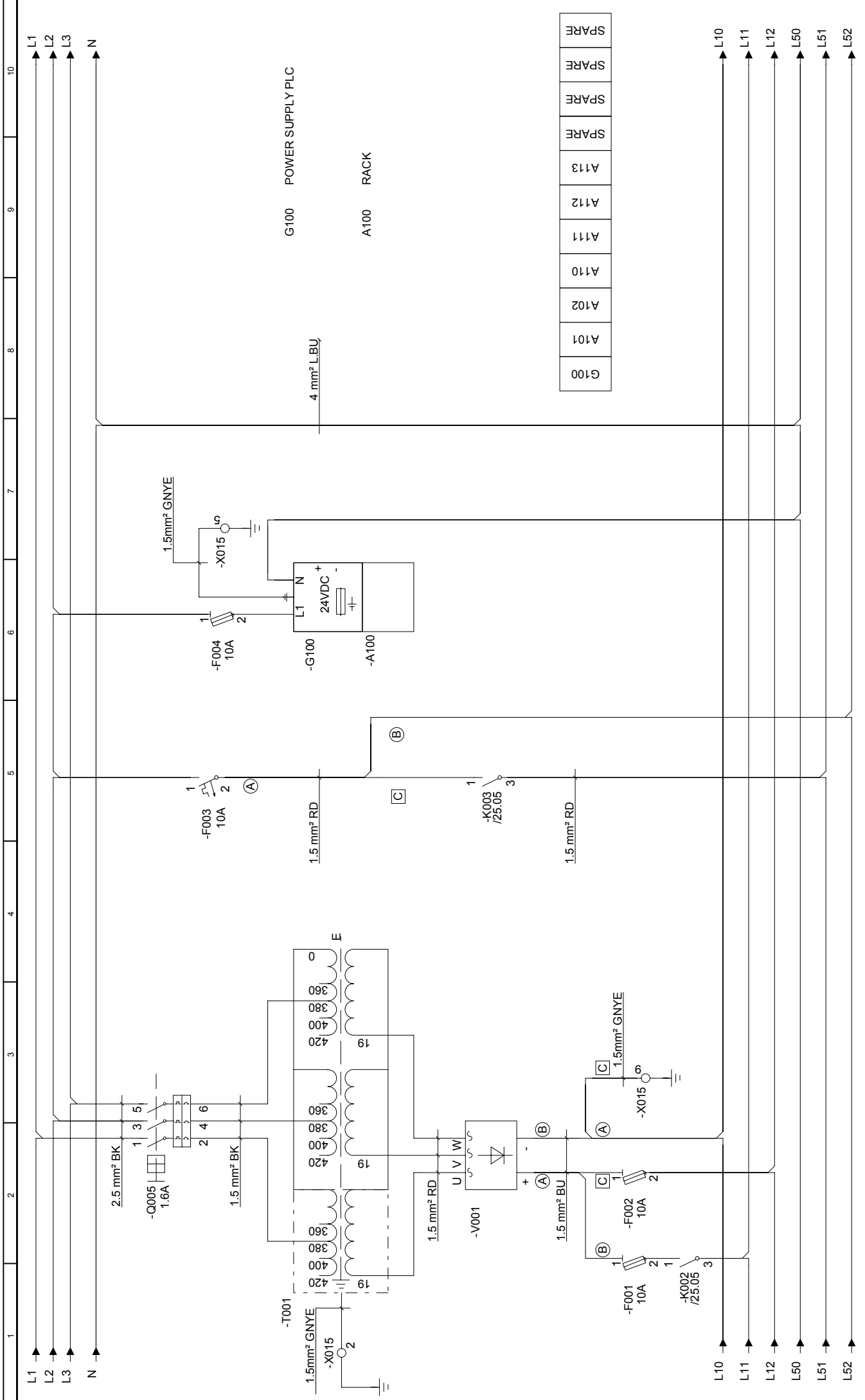

1	2	3	4	5	6	7	8	9	10
<p>Designer: LUP          Date: 25/05/2007          Machine: SCUJ4-0150          Denomination: CIRCUIT DIAGRAM          Page Type: CONTROL VOLTAGE, PLC          ECM No: 303930          Document No.: 2895133-0003          Version: AA          Page: 007</p>									
<p>Company: Tetra Pak (Italy)          Drawing remarks:</p>									

1 2 3 4 5 6 7 8 9 10

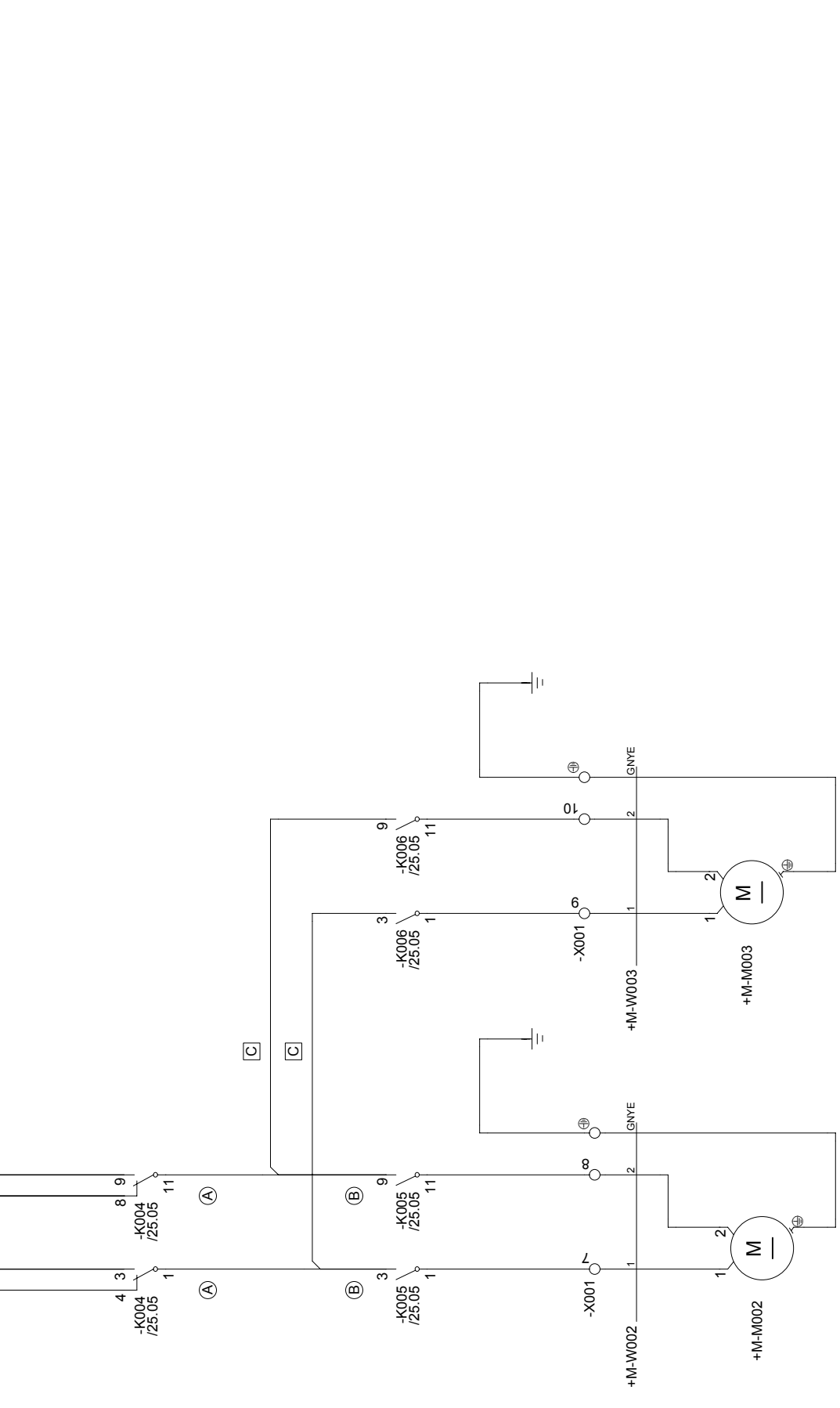

ALKALI PUMP

ACID PUMP

Designer LUP		Date 25/05/2007	Machine SCUJ4-0150
ECM No 303930		Page Type DC MOTORS	
Denomination		CIRCUIT DIAGRAM	
Company Tetra Pak (Italy)		Document No. 2895133-0003	Doc. type ELD
Drawing remarks		Version AA	Page 008

1 2 3 4 5 6 7 8 9 10

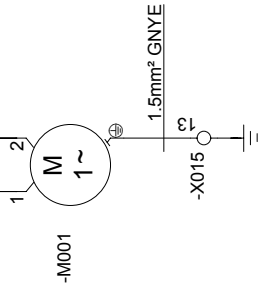
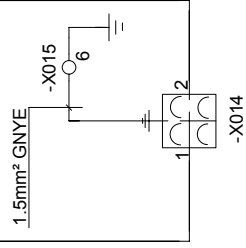
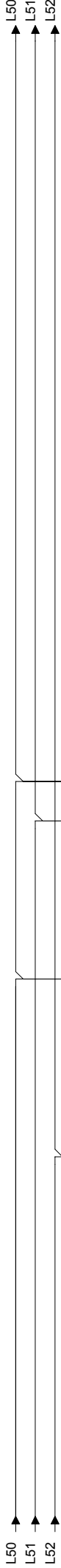

WALL SOCKET

ELECTRICAL CABINET FAN

<b>Tetra Pak</b>		Designer LUP	Date 25/05/2007	Machine SCUJ4-0150
Company Tetra Pak (Italy)		ECM No 303930	Denomination CIRCUIT DIAGRAM	Page Type FAN SOCKET
Drawing remarks		Document No. 2895133-0003		Doc. type ELD
				Version AA
				Page 009

1 2 3 4 5 6 7 8 9 10

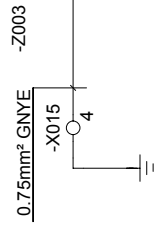
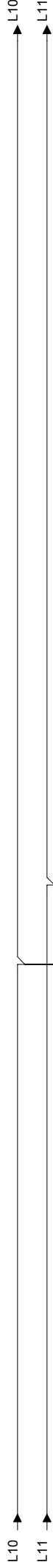

A001 CIP CONDUCTIVITY METER

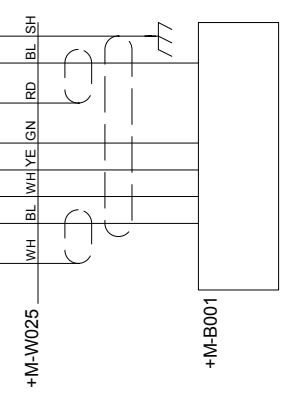
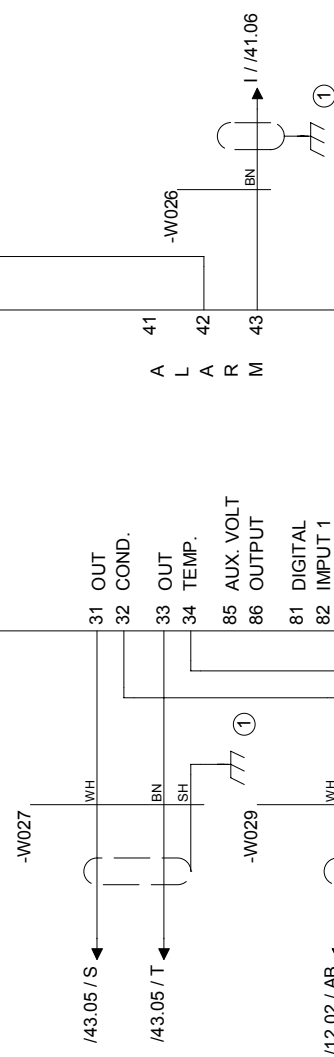
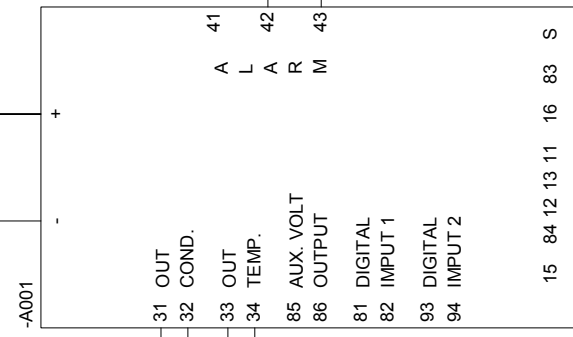

B001 CIP CONDUCTIVITY/TEMPERATURE SENSOR

Designer	LUP	Date	25/05/2007	Machine	SCU/4-0150
ECM No	303930	Denomination	CIRCUIT DIAGRAM		
Company		Tetra Pak (Italy)			
Drawing remarks		Doc. type		Version	Page
		2895133-0003		ELD AA	010
		CONDUCTIVITY METER			

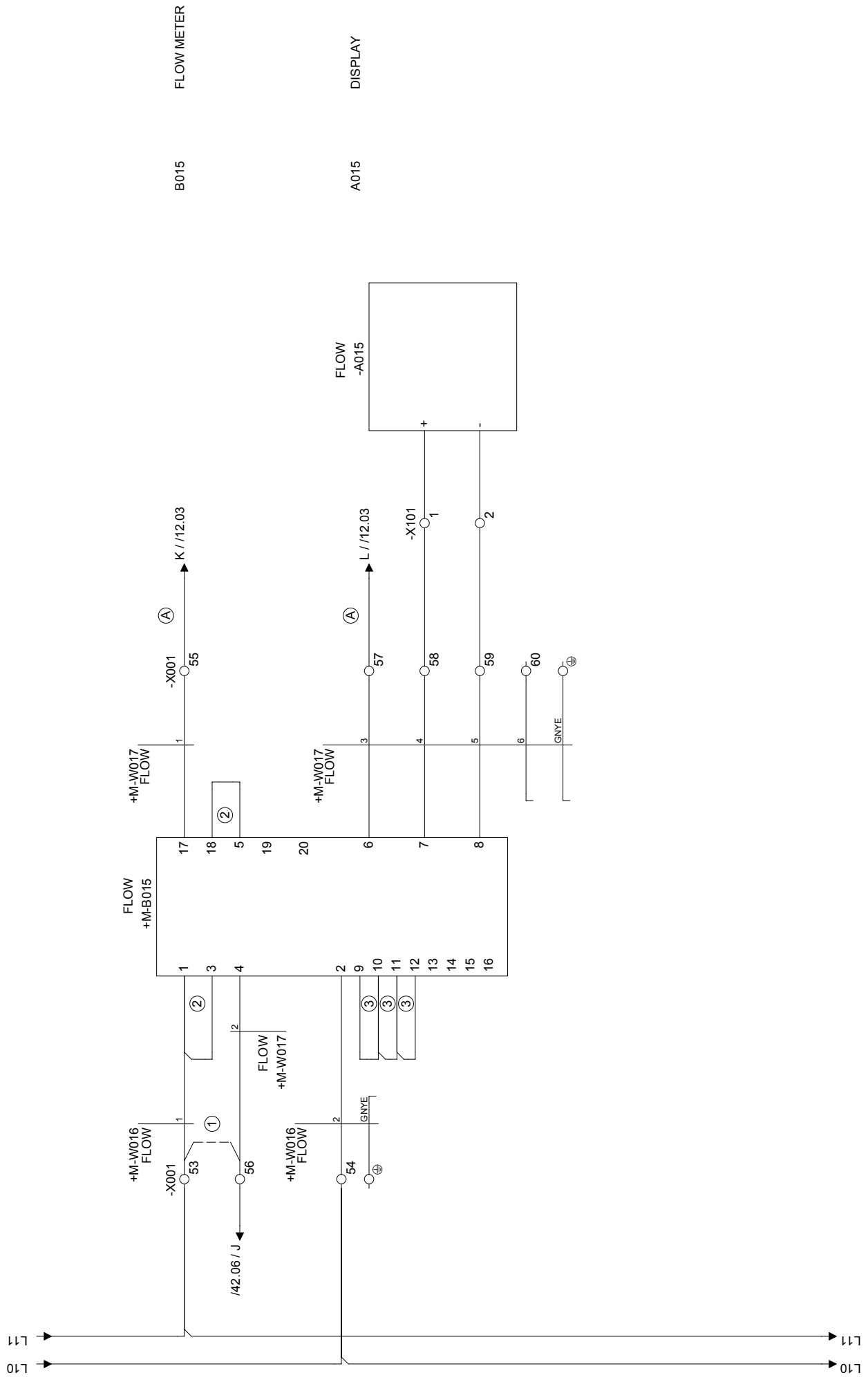

Designer	LUP	Date	25/05/2007	Machine	SCU/4-0150
ECM No	303930	Denomination	CIRCUIT DIAGRAM	Page Type	FLOW METER
Company	Tetra Pak (Italy)		Document No.	2895133-0003	Doc. type
Drawing remarks			Version	AA	Page
				ELD	011

1 2 3 4 5 6 7 8 9 10

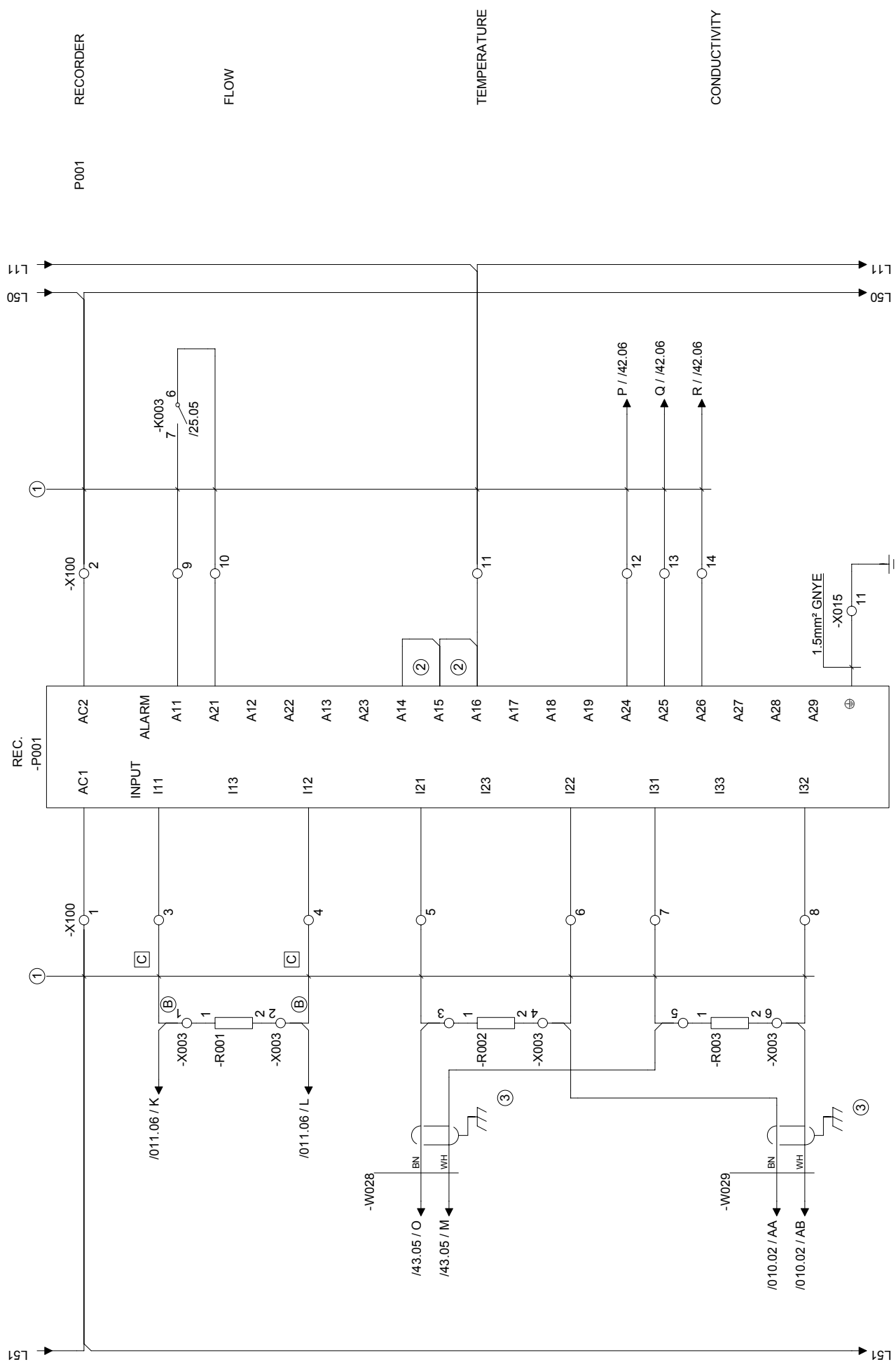

Designer	LUP	Date	25/05/2007	Machine	SCU/4-0150
ECM No	303930	Denomination	CIRCUIT DIAGRAM	Page Type	RECORDER
Company	Tetra Pak (Italy)		Document No.	2895133-0003	Doc. type
	Drawing remarks			ELD	Version
				AA	Page
					12

1 2 3 4 5 6 7 8 9 10

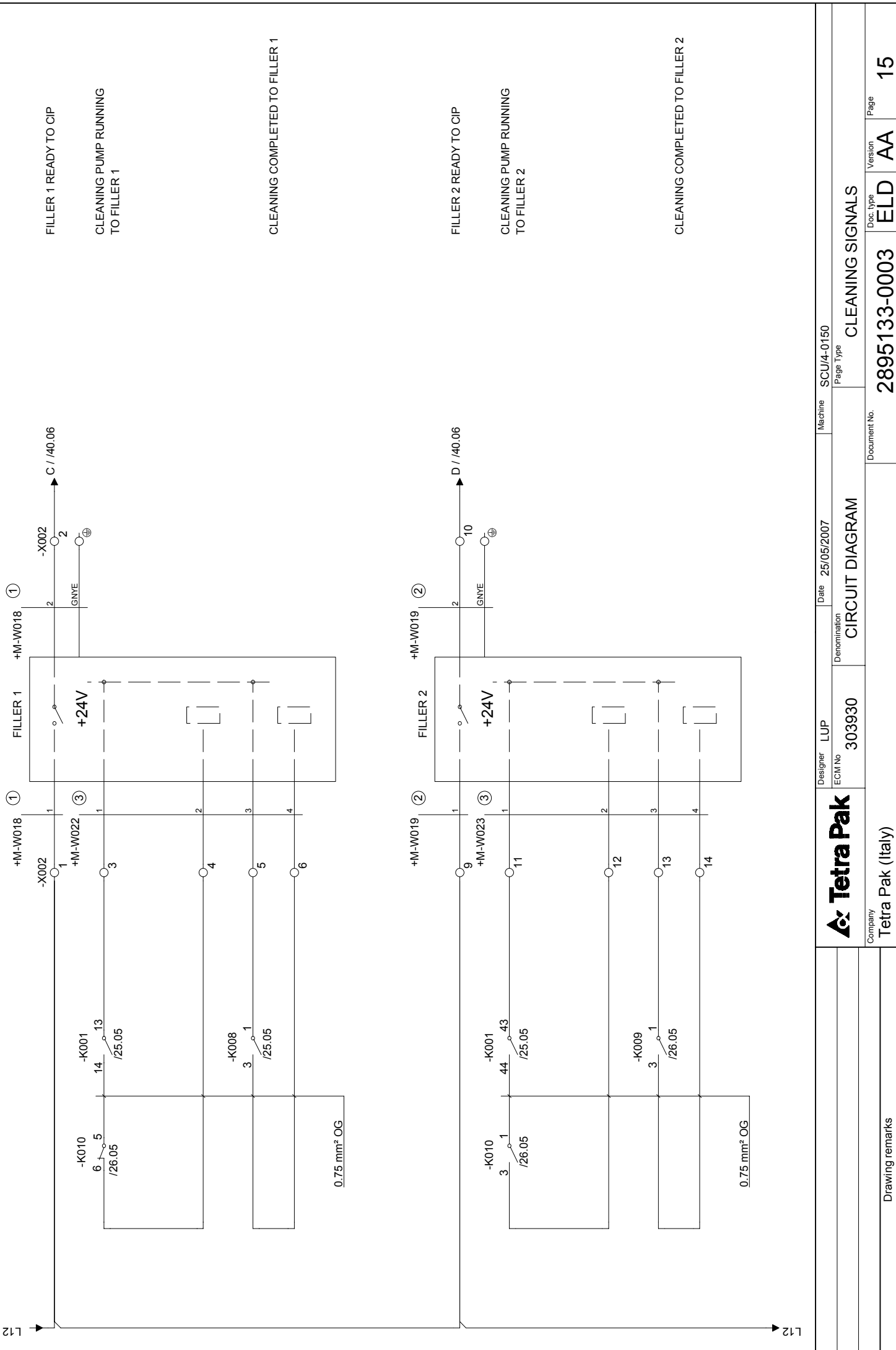

FILLER 1 READY TO CIP  
CLEANING PUMP RUNNING  
TO FILLER 1

CLEANING COMPLETED TO FILLER 1

FILLER 2 READY TO CIP  
CLEANING PUMP RUNNING  
TO FILLER 2

CLEANING COMPLETED TO FILLER 2

Designer LUP	Date 25/05/2007	Machine SCU/4-0150
ECM No 303930	Denomination CIRCUIT DIAGRAM	Page Type CLEANING SIGNALS
Company Tetra Pak (Italy)		Doc. type ELD
Drawing remarks		Version AA
		Page 15

1 2 3 4 5 6 7 8 9 10

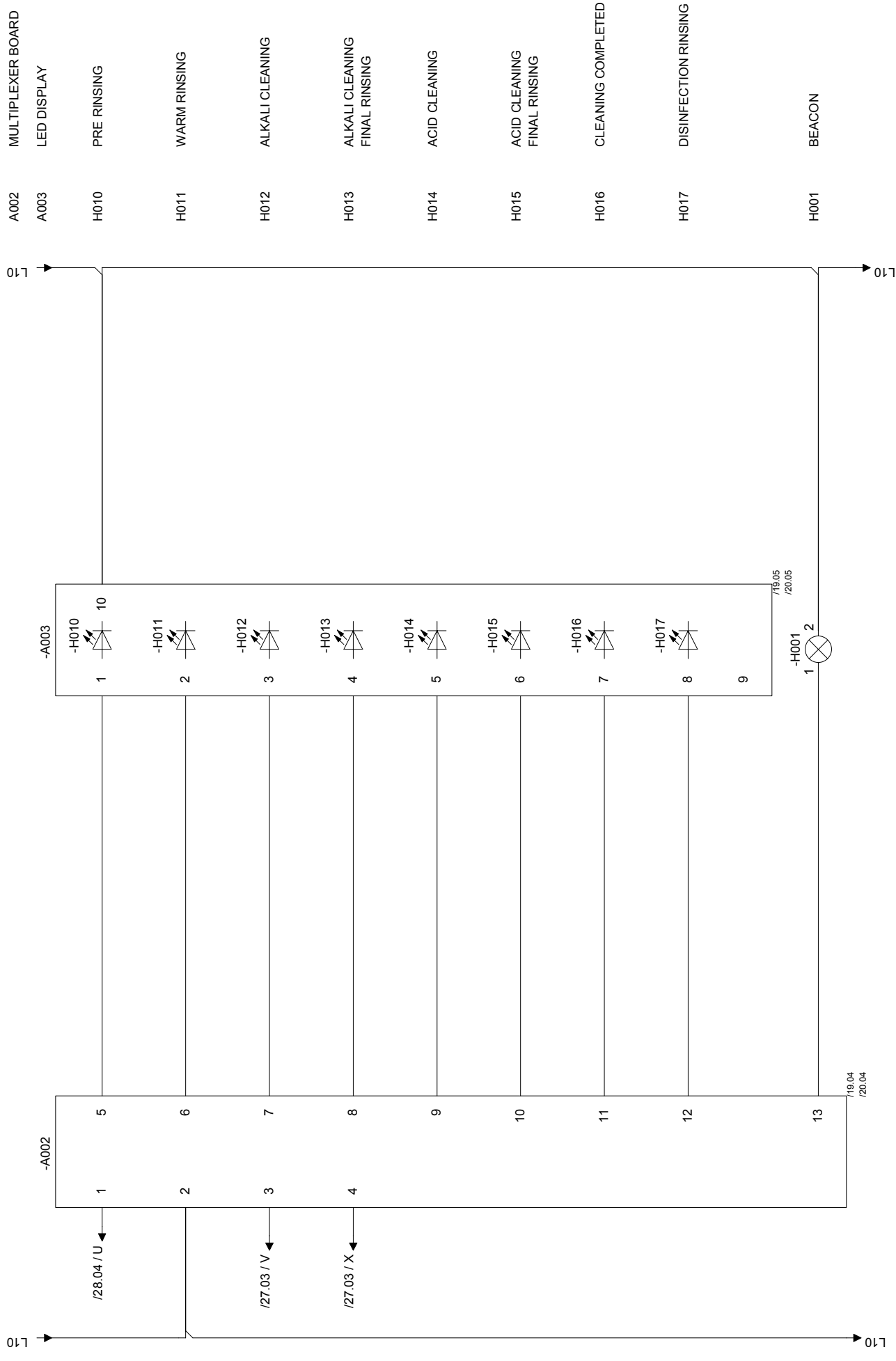

Machine	SCU/4-0150	Page Type	MULTIPLIER BOARD	Version	AA	Page	18
Date	25/05/2007	Denomination	CIRCUIT DIAGRAM	Doc. type	ELD	Document No.	2895133-0003
Designer	LUP	ECM No	303930	Company			
Tetra Pak				Tetra Pak (Italy)			
Drawing remarks							

1 2 3 4 5 6 7 8 9 10

MULTIPLEXER BOARD

- A002 LED DISPLAY
- A003 CHANGE OVER VALVE IN WRONG POSITION
- H018 MAIN TANK MAX LEVEL NOT REACHED
- H019 MAIN TANK INTERMEDIATE LEVEL NOT REACHED
- H020 MAIN TANK EMPTYING TOO SLOW
- H021 INCORRECT CONDUCTIVITY VALUE
- H022 ALKALI AUTOLOAD QUICK CONNECTOR IN WRONG POSITION
- H023 ACID AUTOLOAD QUICK CONNECTOR IN WRONG POSITION
- H024 ALKALI AUTOLOAD TIME TOO LONG
- H025 ALKALI TANK ALMOST EMPTY
- H026 ALKALI AUTOLOAD TIME TOO LONG

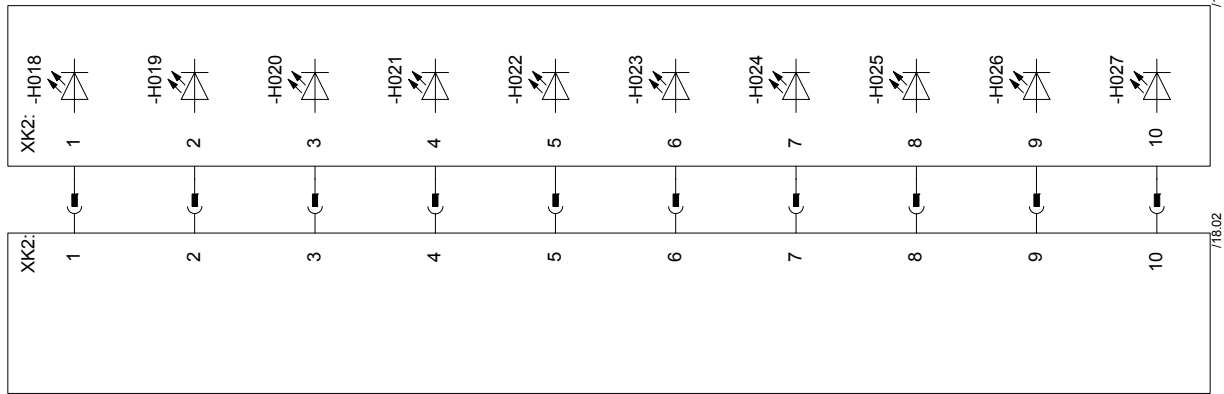

Machine	SCU/4-0150
Date	25/05/2007
Denomination	CIRCUIT DIAGRAM
Designer	LUP
ECM No	303930
Document No.	2895133-0003
Doc. type	ELD
Version	AA
Page	19



Company  
Tetra Pak (Italy)

Drawing remarks

1 2 3 4 5 6 7 8 9 10

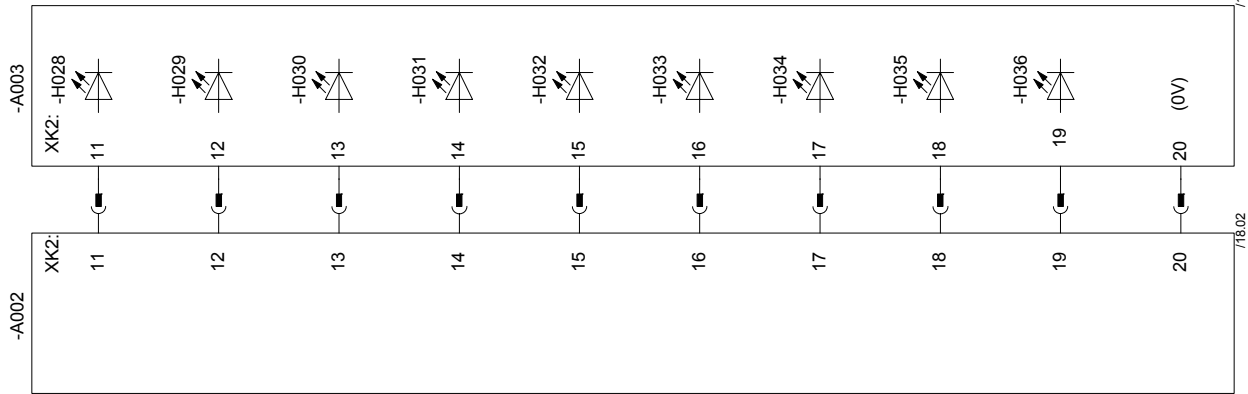

A002	MULTIPLEXER BOARD
A003	LED DISPLAY
H028	ACID TANK ALMOST EMPTY
H029	SURGE FILTER ACTIVATED
H030	LOW CLEANING FLOW
H031	SELECTED FILLERS NOT READY FOR CIP
H032	CLEANING PUMP OVERLOAD
H033	EMERGENCY STOP ACTIVATED
H034	STEAM SUPPLY
H035	WATER SUPPLY
H036	LOW AIR PRESSURE

Machine	SCU/4-0150
Date	25/05/2007
Denomination	CIRCUIT DIAGRAM
Page Type	MULTIPLEXER BOARD - ALARMS
Doc. type	ELD
Version	AA
Document No.	2895133-0003
Page	20

Designer LUP  
ECM No 303930

**Tetra Pak**  
Company Tetra Pak (Italy)

Drawing remarks

1 2 3 4 5 6 7 8 9 10

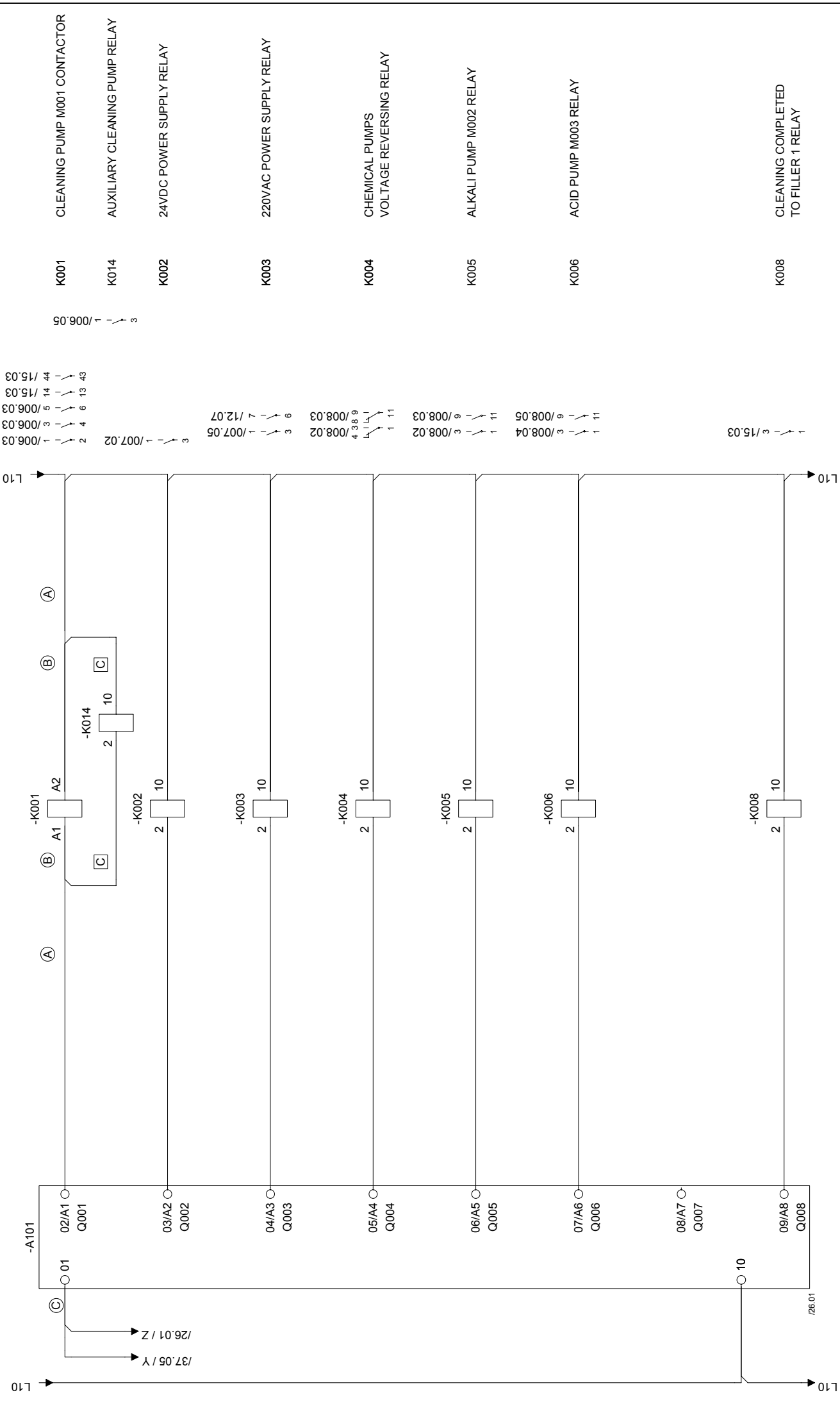

Designer	LUP	Date	25/05/2007	Machine	SCU/4-0150
ECM No	303930	Denomination	CIRCUIT DIAGRAM	Page Type	PLC-OUT, RELAY
Company	Tetra Pak (Italy)		Document No.	2895133-0003	Version
Drawing remarks				ELD	AA
					25

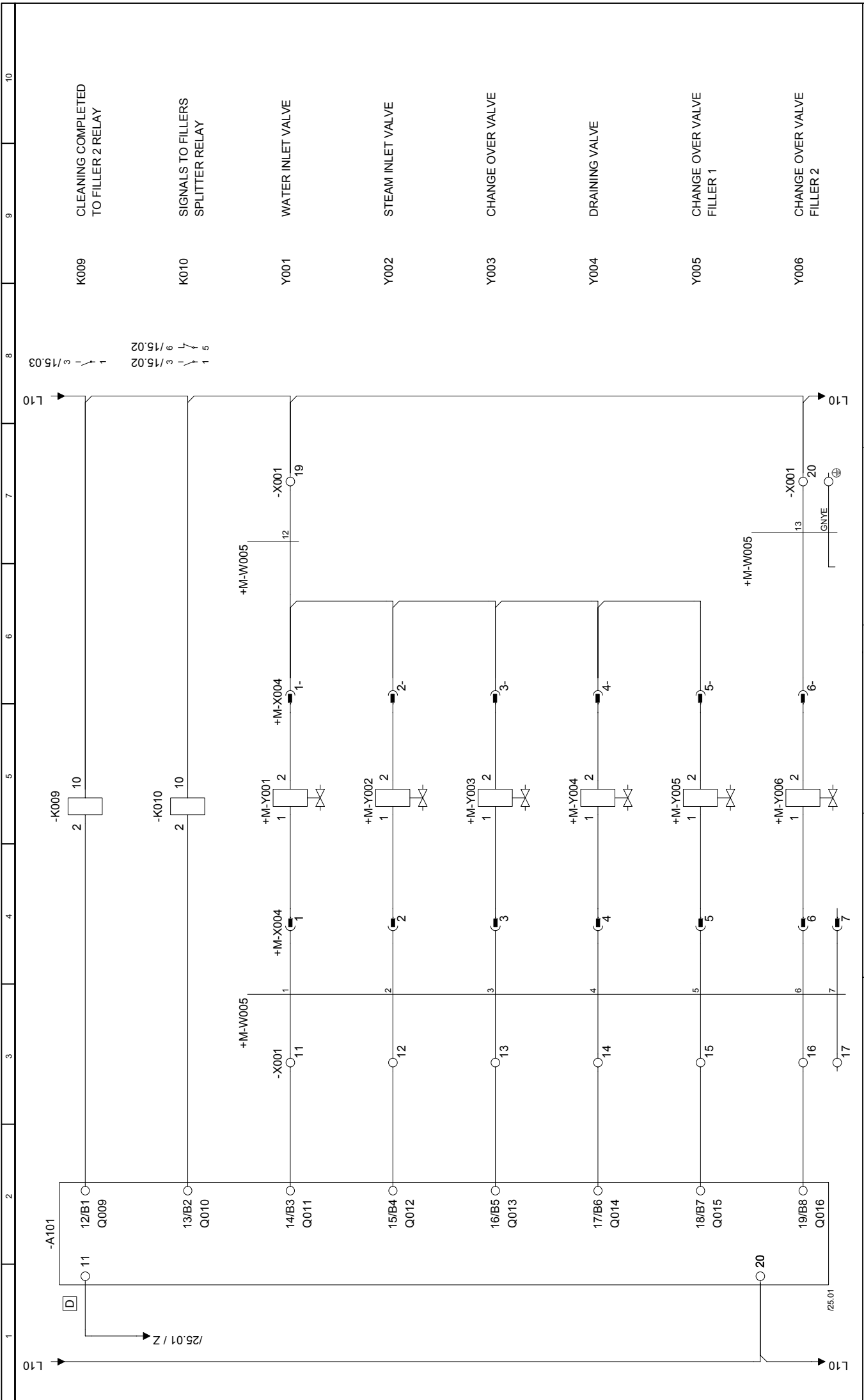

1 /15.03 3 /15.02 1 /15.02 3 /15.02 1 /15.02 3 /15.02 1 /15.02 3 /15.02 1 /15.02 3 /15.02

1	2	3	4	5	6	7	8	9	10
<p>Machine SCUJ4-0150          Date 25/05/2007          Designer LUP          Denomination 303930          Document No. 2895133-0003          Page Type PLC-OUT, VALVES          Version AA          Page 26</p>									
<p>Company Tetra Pak (Italy)          Drawing remarks</p>									

1 2 3 4 5 6 7 8 9 10

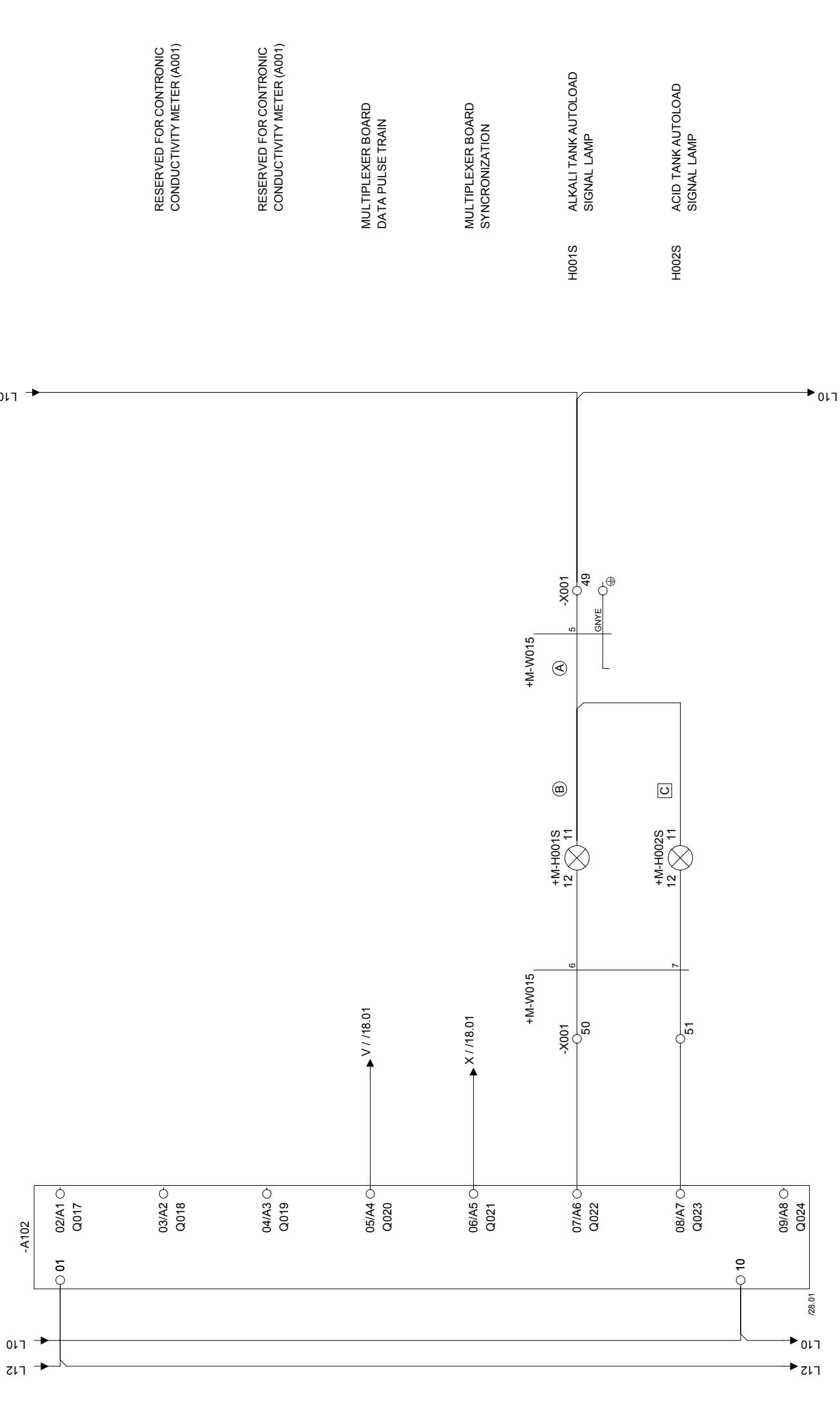

RESERVED FOR CONTRONIC CONDUCTIVITY METER (A001)

RESERVED FOR CONTRONIC CONDUCTIVITY METER (A001)

MULTIPLER BOARD DATA PULSE TRAIN

MULTIPLER BOARD SYNCHRONIZATION

H001S ALKALI TANK AUTOLOAD SIGNAL LAMP

H002S ACID TANK AUTOLOAD SIGNAL LAMP

Designer	LUP	Date	25/05/2007	Machine	SCU/4-0150
ECM No	303930	Denomination	CIRCUIT DIAGRAM	Page Type	PLC-OUT, SIGNALS
Company	Tetra Pak (Italy)		Document No.	2895133-0003	Version
Drawing remarks				ELD	AA
					27

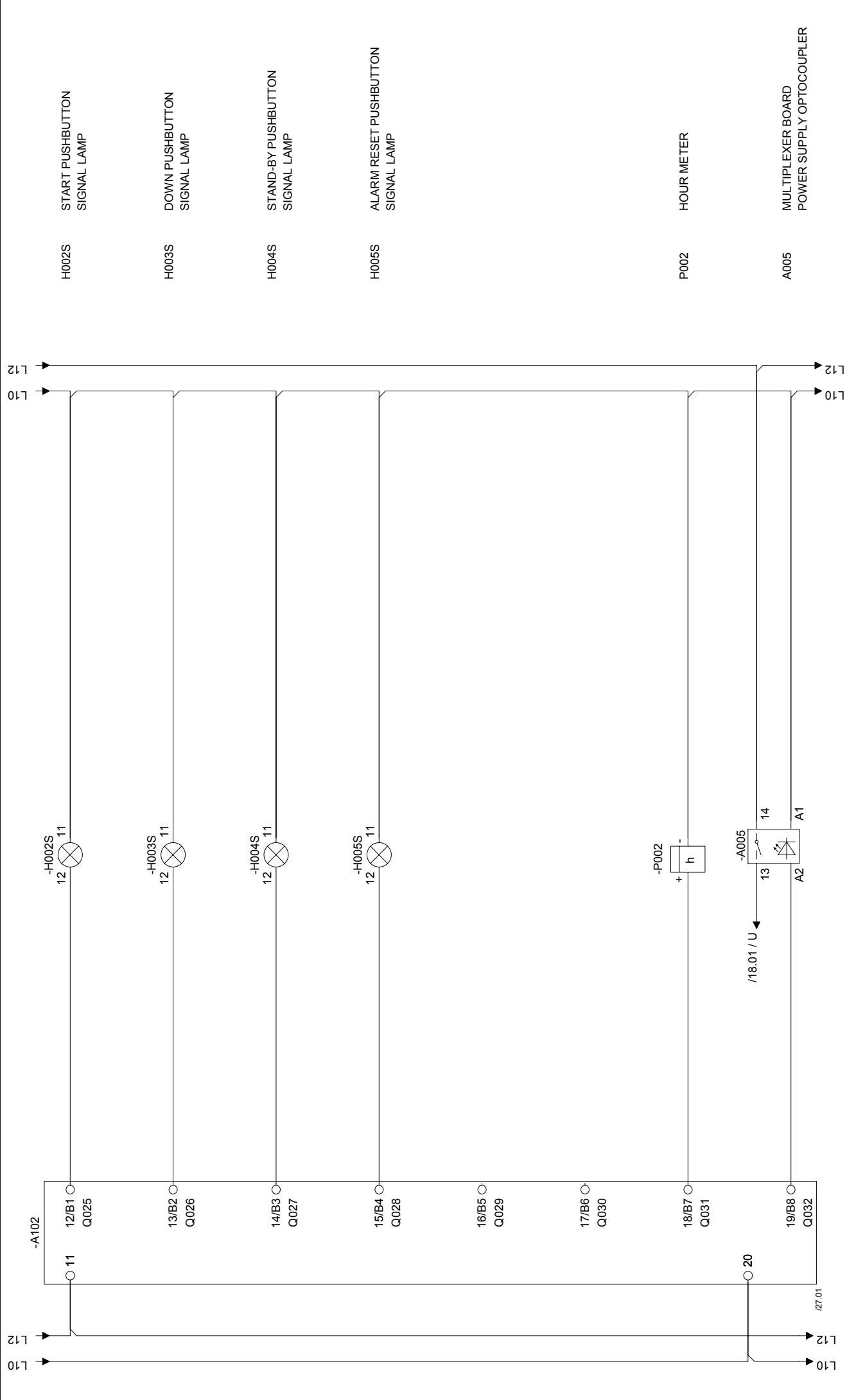

Designer LUP	Date 25/05/2007	Machine SCU/4-0150	Page Type PLC-OUT, SIGNAL LAMPS
ECM No 303930	Denomination CIRCUIT DIAGRAM	Document No. 2895133-0003	Doc. type ELD
Company Tetra Pak (Italy)			Version AA
Drawing remarks			Page 28

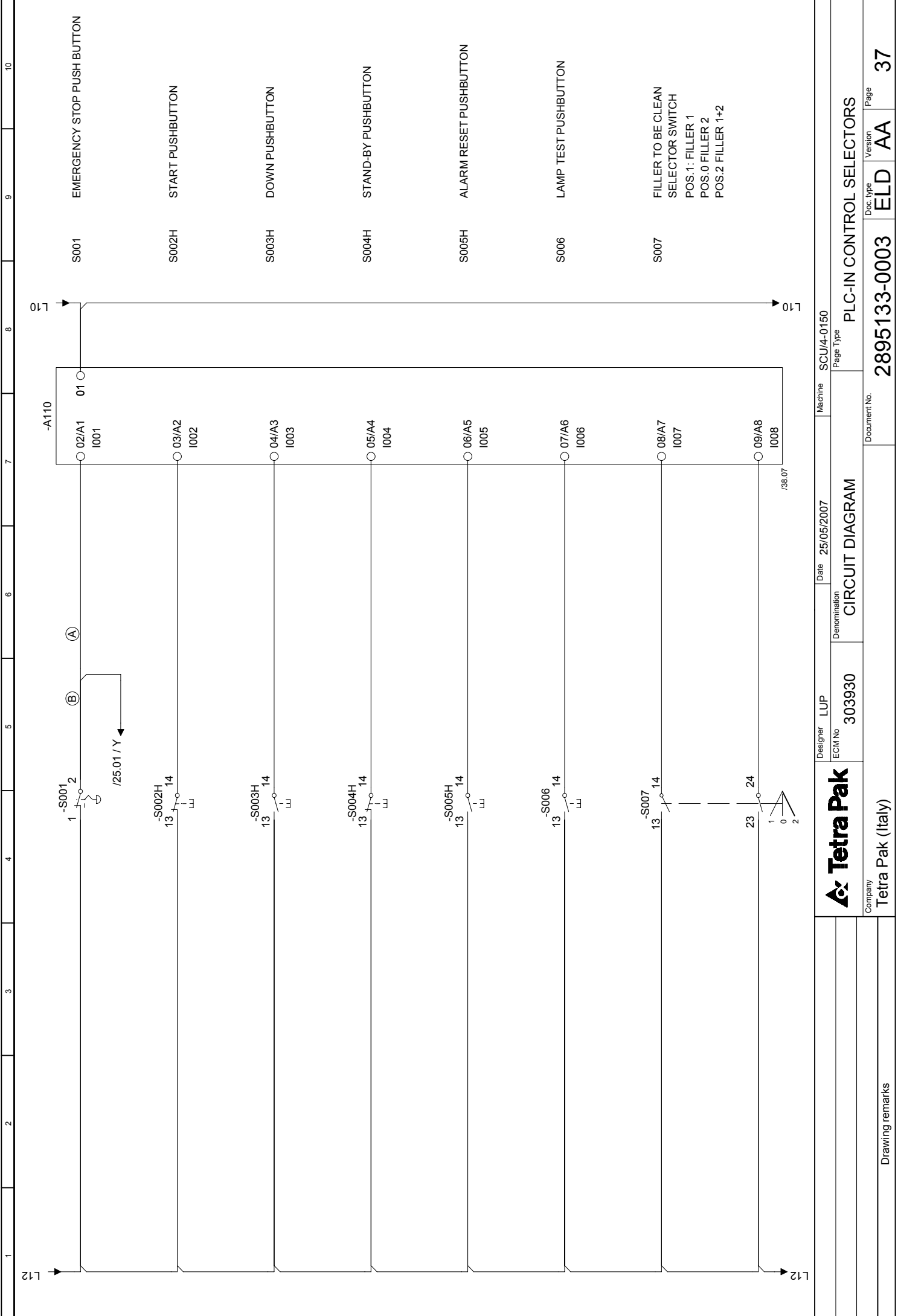

1 2 3 4 5 6 7 8 9 10

L 12 L 10

Machine	SCU/4-0150
Page Type	PLC-IN CONTROL SELECTORS
Denomination	CIRCUIT DIAGRAM
Designer	LUP
ECM No	303930
Date	25/05/2007
Document No.	2895133-0003
Doc. type	ELD
Version	AA
Page	37

Company  
Tetra Pak (Italy)

Drawing remarks

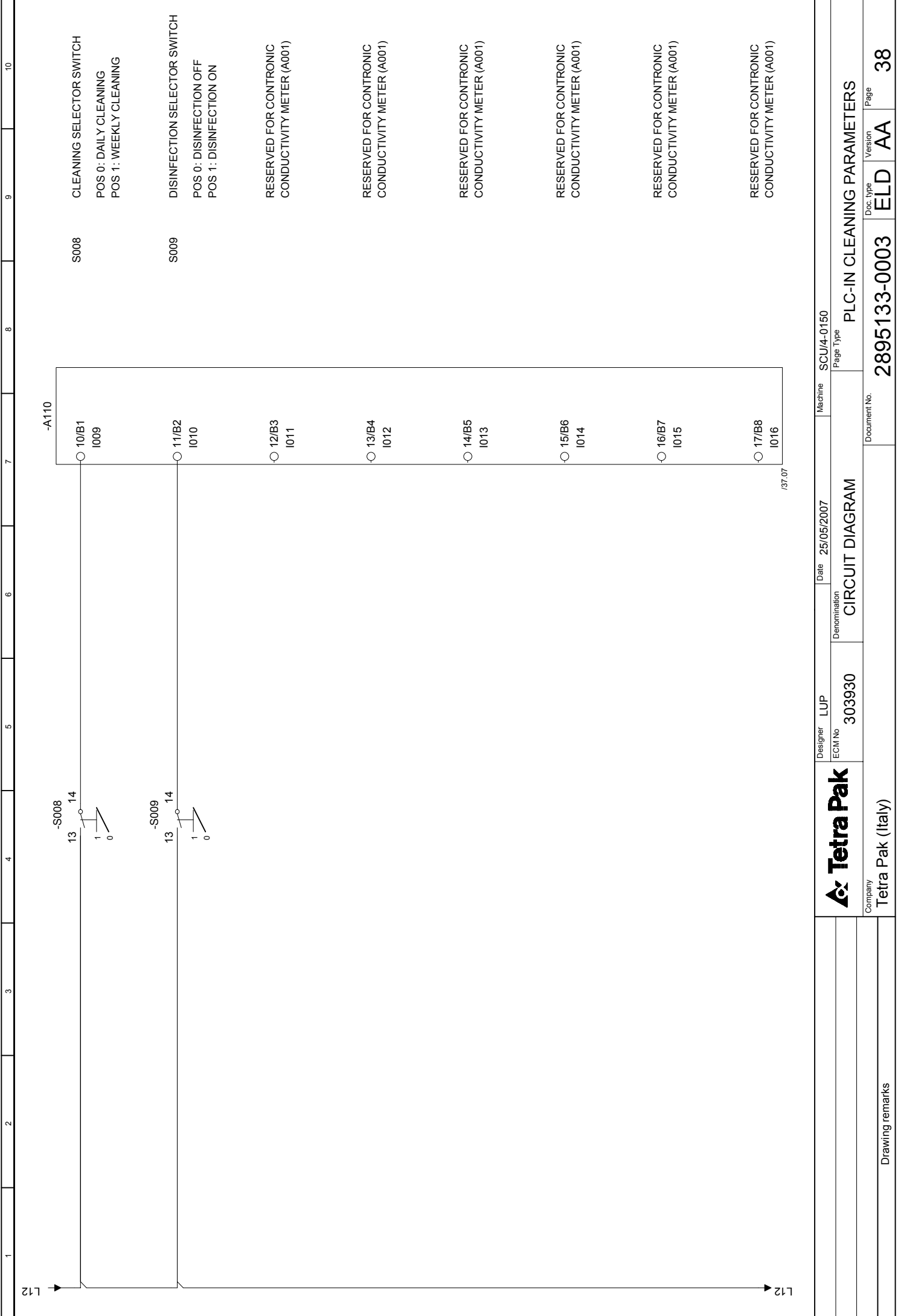

1	2	3	4	5	6	7	8	9	10
		Designer LUP ECM No 303930	Date 25/05/2007	Machine SCUJ4-0150	Page Type PLC-IN CLEANING PARAMETERS	Doc. type ELD	Version AA	Page 38	Document No. 2895133-0003
Denomination CIRCUIT DIAGRAM				Company Tetra Pak (Italy)					
Drawing remarks									

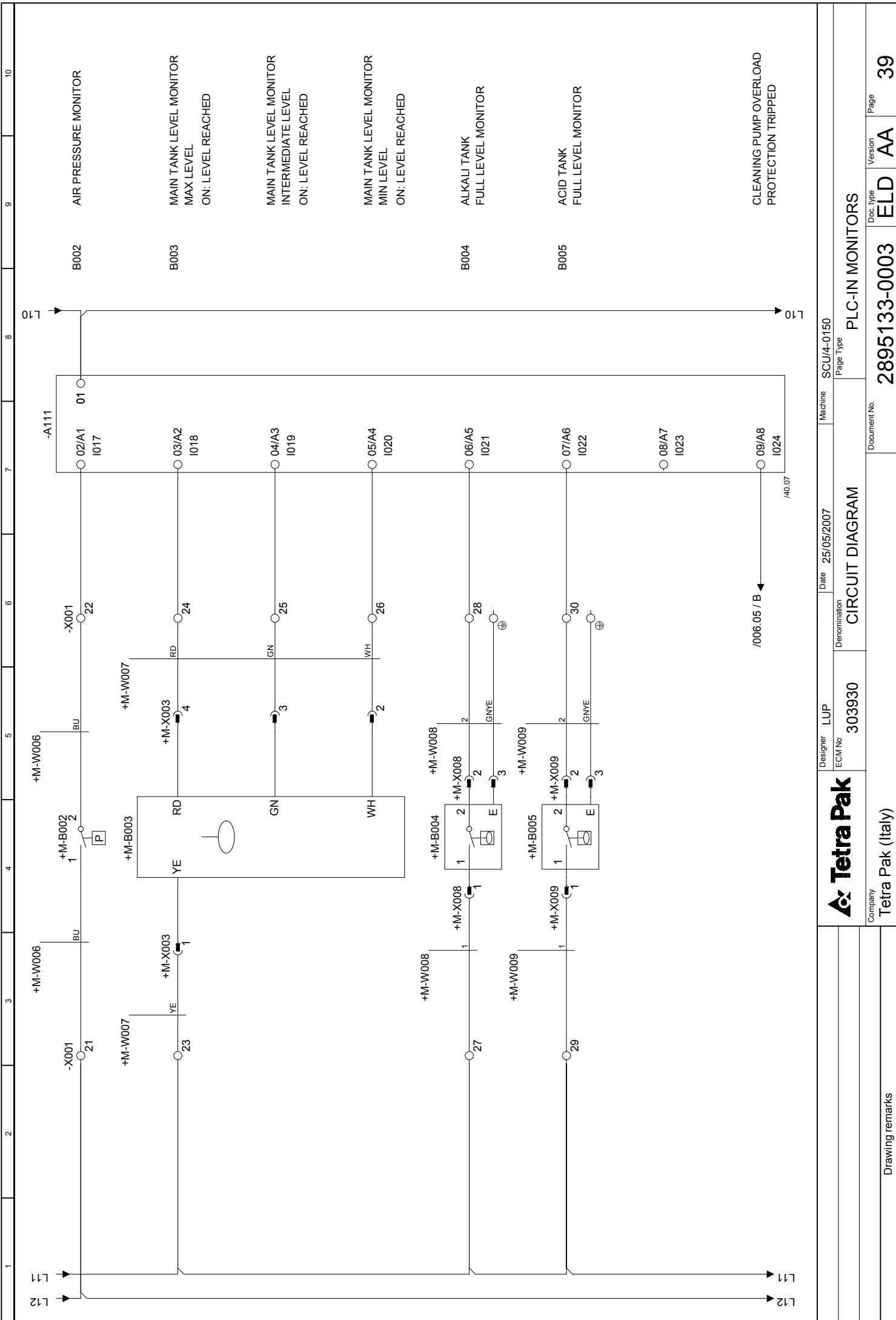

B002 AIR PRESSURE MONITOR

B003 MAIN TANK LEVEL MONITOR  
MAX LEVEL  
ON: LEVEL REACHED

MAIN TANK LEVEL MONITOR  
INTERMEDIATE LEVEL  
ON: LEVEL REACHED

MAIN TANK LEVEL MONITOR  
MIN LEVEL  
ON: LEVEL REACHED

B004 ALKALI TANK  
FULL LEVEL MONITOR

B005 ACID TANK  
FULL LEVEL MONITOR

CLEANING PUMP OVERLOAD  
PROTECTION TRIPPED

Machine	SCU/4-0150
Page Type	PLC-IN MONITORS
Denomination	CIRCUIT DIAGRAM
Designer	LUP
ECM No	303930
Date	25/05/2007
Document No.	2895133-0003
Doc. type	ELD
Version	AA
Page	39

Drawing remarks

1 2 3 4 5 6 7 8 9 10

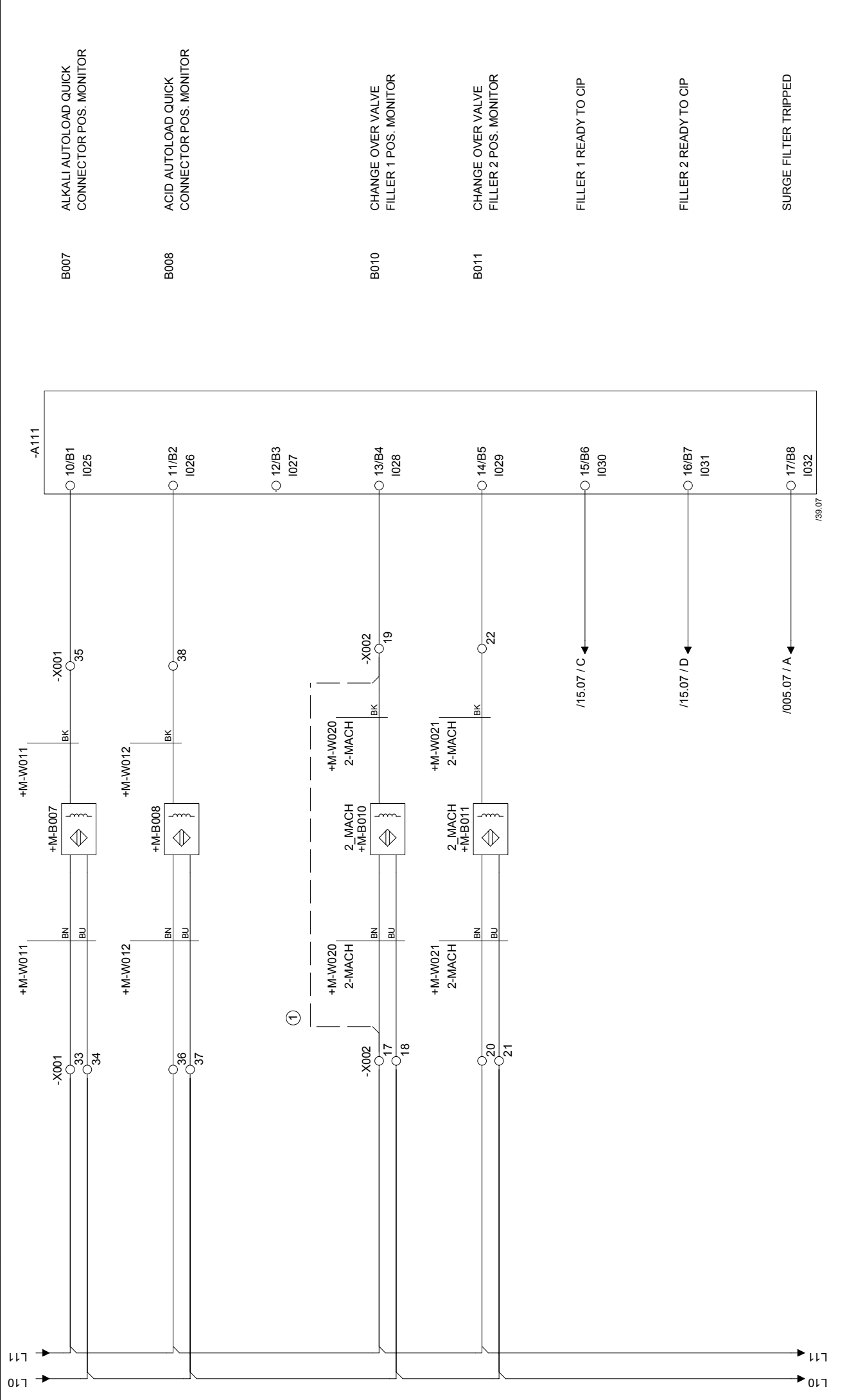

Designer LUP		Date 25/05/2007	Machine SCUJ4-0150
ECM No 303930		Denomination	Page Type
Company Tetra Pak (Italy)		CIRCUIT DIAGRAM	PLC-IN OPERATION MONITORS
Drawing remarks		Document No. 2895133-0003	Doc. type ELD
		Version AA	Page 40

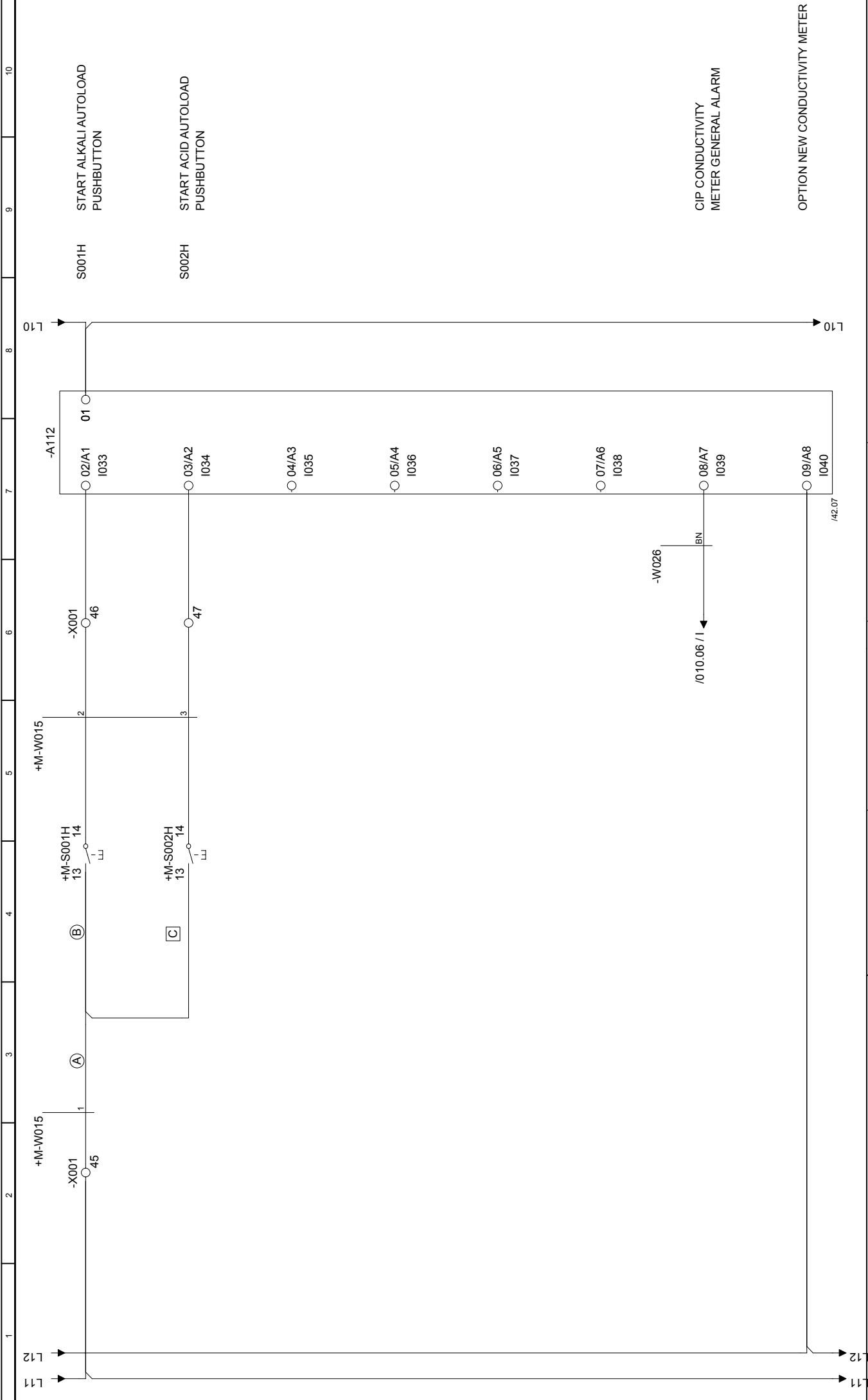

1	2	3	4	5	6	7	8	9	10
<p>Designer: LUP ECM No: 303930 Date: 25/05/2007 Machine: SCUJ4-0150 Denomination: CIRCUIT DIAGRAM Page Type: MACHINE SELECTORS</p>									
<p>Company: Tetra Pak (Italy) Document No.: 2895133-0003 Doc. type: ELD Version: AA Page: 41</p>									
<p>Drawing remarks</p>									

1 2 3 4 5 6 7 8 9 10

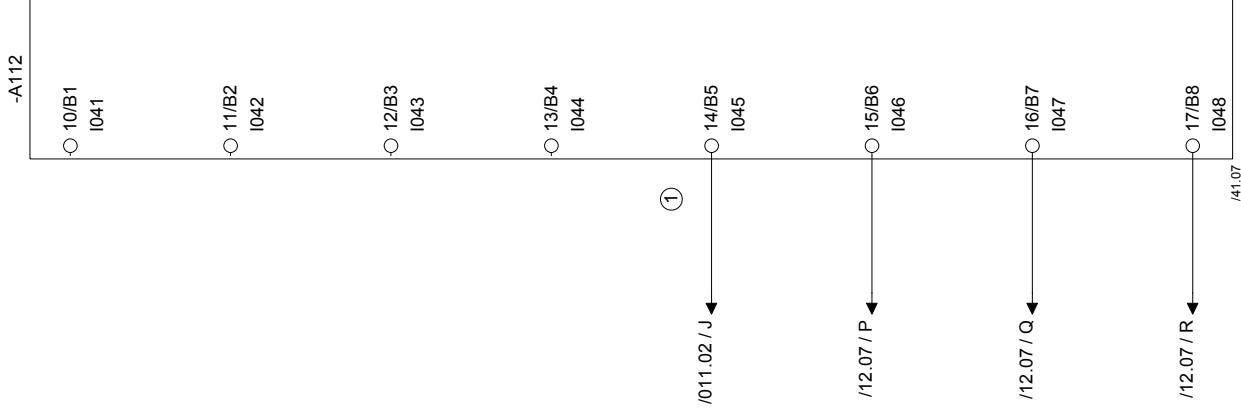

		Designer LUP ECM No 303930	Date 25/05/2007	Machine SCUJ4-0150	Page Type
Company Tetra Pak (Italy)		Denomination CIRCUIT DIAGRAM		PLC-IN, CLEANING MONITORS	
Drawing remarks		Document No. 2895133-0003		Doc. type ELD	Version AA
				Page 42	

1 2 3 4 5 6 7 8 9 10

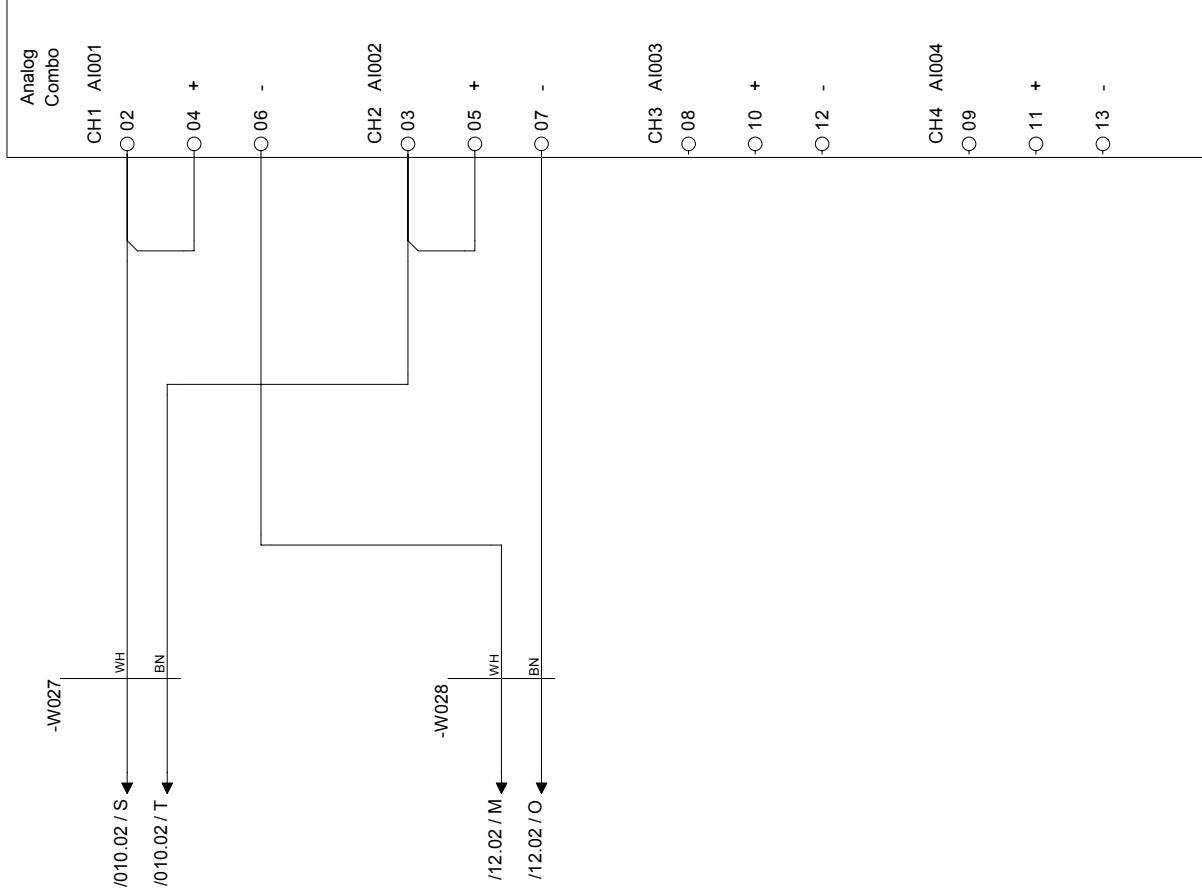

Designer LUP		Date 25/05/2007	Machine SCUJ4-0150
ECM No 303930		Denomination CIRCUIT DIAGRAM	Page Type PLC ANALOG INPUT
Company Tetra Pak (Italy)		Document No. 2895133-0003	Doc. type ELD
Drawing remarks		Version AA	Page 43

1 2 3 4 5 6 7 8 9 10

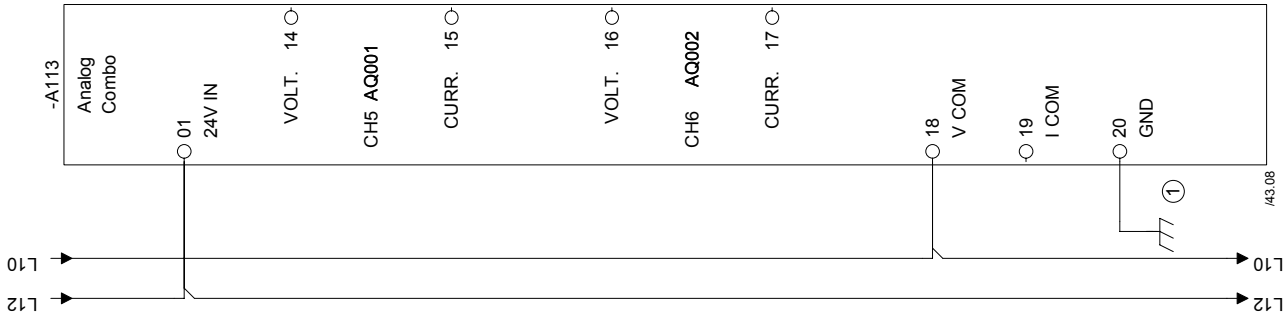

		Designer LUP ECM No 303930	Date 25/05/2007	Machine SCUJ4-0150
Company Tetra Pak (Italy)		Denomination CIRCUIT DIAGRAM		
Document No. 2895133-0003		Page Type PLC ANALOG OUTPUT		
Drawing remarks		Doc. type ELD	Version AA	Page 44

1 2 3 4 5 6 7 8 9 10

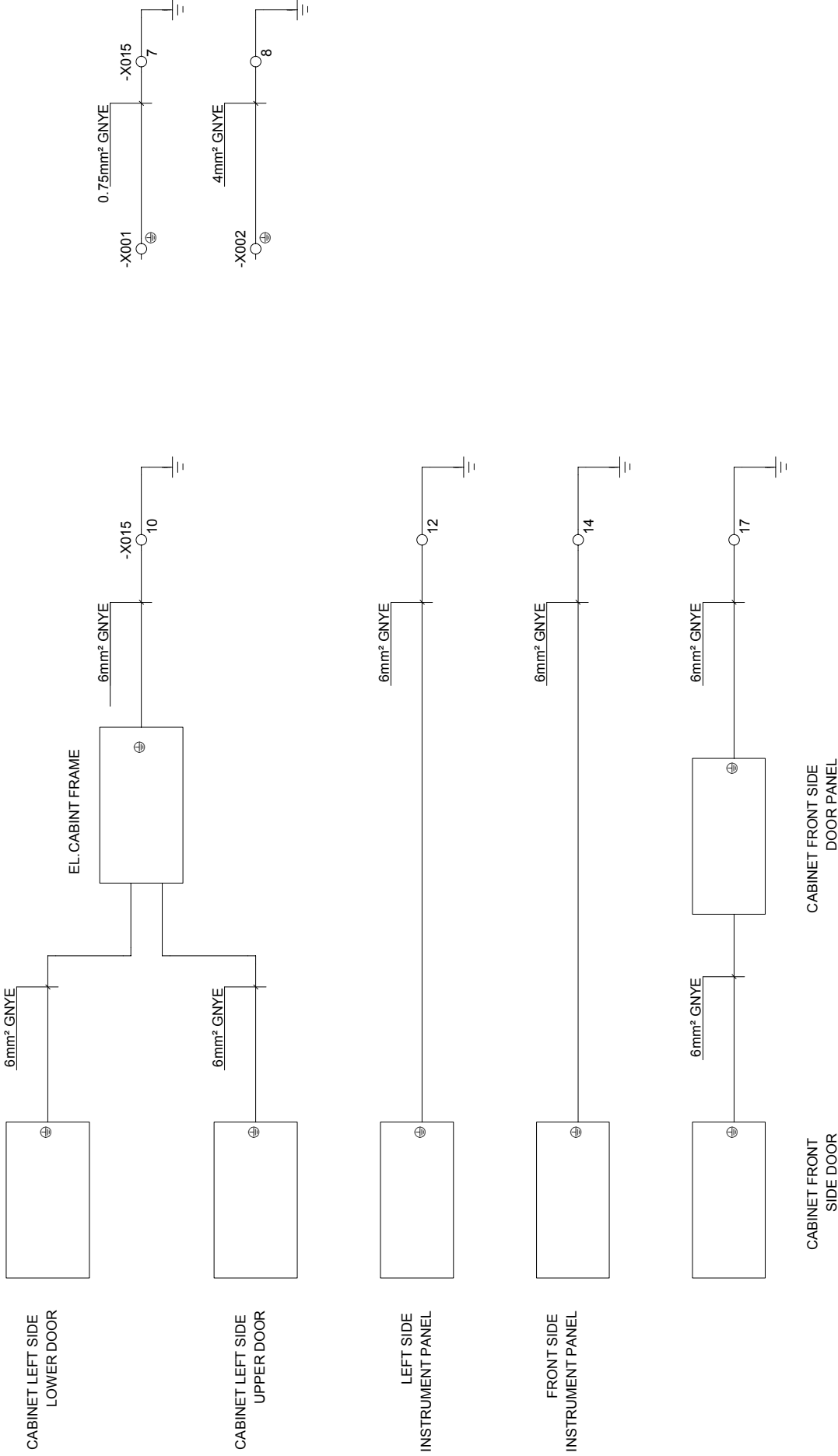

Designer	LUP	Date	25/05/2007	Machine	SCU/4-0150
ECM No	303930	Denomination	CIRCUIT DIAGRAM	Page Type	GROUNDING CONNECTIONS
Company	Tetra Pak (Italy)		Document No.	2895133-0003	Doc. type
Drawing remarks				ELD	AA
					Page
					45

# 5 Line Summary

TechPub\_2614345\_v3\_DRAFT\_Release05\_EM2890021\_01.en.fm

### Description

All connections inside the electrical cabinet are listed in this chapter.

Line summary of 2895133-0003

Line	From	Page.Col.	To	Page.Col.	Area/Color	Opt.
L10	+C-XL010:1	001.1	+C-V001:-	007.2	1.5 mm <sup>2</sup> BU	
	+C-V001:-	007.2	+C-X015:9	007.3		
	+C-XL010:2	001.1	+C-A101:10	25.1	0.75 mm <sup>2</sup> BU	
	+C-A101:10	25.1	+C-A101:20	26.1		
	+C-XL010:3	001.1	+C-A102:10	27.1	0.75 mm <sup>2</sup> BU	
	+C-A102:10	27.1	+C-A102:20	28.1		
	+C-XL010:4	001.2	+C-A110:01	37.8	0.75 mm <sup>2</sup> BU	
	+C-XL010:5	001.2	+C-A111:01	39.8	0.75 mm <sup>2</sup> BU	
	+C-XL010:6	001.2	+C-A112:01	41.8	0.75 mm <sup>2</sup> BU	
	+C-A112:01	41.8	+C-A113:18	44.1		
	+C-XL010:7	001.2	+C-X001:19	26.7	0.75 mm <sup>2</sup> BU	
	+C-X001:19	26.7	+C-X001:20	26.7		
	+C-X001:20	26.7	+C-X001:34	40.3		
	+C-X001:34	40.3	+C-X001:34	40.3		
	+C-X001:34	40.3	+C-X001:37	40.3		
	+C-X001:37	40.3	+C-X001:49	27.6		
	+C-X001:49	27.6	+C-X001:54	011.2		
	+C-XL010:8	001.2	+C-X002:18	40.3	0.75 mm <sup>2</sup> BU	
	+C-X002:18	40.3	+C-X002:21	40.3		
	+C-XL010:9	001.2	+C-K004:3	008.2	0.75 mm <sup>2</sup> BU	
	+C-K004:3	008.2	+C-K004:8	008.3		
	+C-XL010:10	001.2	+C-K001:A2	25.5	0.75 mm <sup>2</sup> BU	
	+C-K001:A2	25.5	+C-K002:10	25.5		
	+C-K002:10	25.5	+C-K003:10	25.5		
	+C-K003:10	25.5	+C-K004:10	25.5		
	+C-K004:10	25.5	+C-A004:A2	006.3		

Line	From	Page.Col.	To	Page.Col.	Area/Color	Opt.
	+C-XL010:11	001.2	+C-K005:10	25.5	0.75 mm <sup>2</sup> BU	
	+C-K005:10	25.5	+C-K006:10	25.5		
	+C-K006:10	25.5	+C-K008:10	25.5		
	+C-K008:10	25.5	+C-K014:10	25.5		
	+C-XL010:12	001.3	+C-K009:10	26.5	0.75 mm <sup>2</sup> BU	
	+C-K009:10	26.5	+C-K010:10	26.5		
	+C-XL010:13	001.3	+C-H002S:11	28.4	0.75 mm <sup>2</sup> BU	
	+C-H002S:11	28.4	+C-H003S:11	28.4		
	+C-H003S:11	28.4	+C-H004S:11	28.4		
	+C-H004S:11	28.4	+C-H005S:11	28.4		
	+C-XL010:15	001.3	+C-A002:2	18.2	0.75 mm <sup>2</sup> BU	
	+C-A002:2	18.2	+C-A003:10	18.6		
	+C-A003:10	18.6	+C-P002:-	28.4		
	+C-XL010:16	001.3	+C-H001:2	18.5	0.75 mm <sup>2</sup> BU	
	+C-XL010:17	001.3	+C-A005:A1	28.4	0.75 mm <sup>2</sup> BU	
	+C-XL010:18	001.3	+C-Z003:N	010.4	0.75 mm <sup>2</sup> BU	

L11

	+C-XL011:1	001.1	+C-K002:3	007.2	1.5 mm <sup>2</sup> BU	
	+C-XL011:2	001.1	+C-K004:4	008.2	0.75 mm <sup>2</sup> BU	
	+C-K004:4	008.2	+C-K004:9	008.3		
	+C-XL011:3	001.1	+C-Z003:P	010.4	0.75 mm <sup>2</sup> BU	
	+C-XL011:4	001.2	+C-X100:11	12.6	0.75 mm <sup>2</sup> BU	
	+C-XL011:5	001.2	+C-X001:23	39.3	0.75 mm <sup>2</sup> BU	
	+C-X001:23	39.3	+C-X001:27	39.3		
	+C-X001:27	39.3	+C-X001:29	39.3		
	+C-XL011:6	001.2	+C-X001:33	40.3	0.75 mm <sup>2</sup> BU	
	+C-X001:33	40.3	+C-X001:36	40.3		

Designer	LUP	Date	25/05/2007	Machine	SCUJ4-0150
ECM No	303930	Denomination	LINE SUMMARY	Page Type	LINE SUMMARY
			Document No. 2895133-0004		
Company Tetra Pak (Italy)			Doc. type ELD		
Drawing remarks			Version AA		
			Page 001		

Line summary of 2895133-0003

Line	From	Page.Col.	To	Page.Col.	Area/Color	Opt.
	+C-X001:36	40.3	+C-X001:45	41.2		
	+C-X001:45	41.2	+C-X001:53	011.2		
	+C-XL011:7	001.2	+C-X002:17	40.3	0.75 mm <sup>2</sup> BU	
	+C-X002:17	40.3	+C-X002:20	40.3		
	+C-XL011:8	001.2	+C-K014:3	006.5	0.75 mm <sup>2</sup> BU	
	+C-K014:3	006.5	+C-A004:A1	006.3		
L12	+C-XL012:1	001.4	+C-F002:2	007.2	1.5 mm <sup>2</sup> BU	
	+C-XL012:2	001.4	+C-A005:14	28.4	0.75 mm <sup>2</sup> BU	
	+C-XL012:3	001.4	+C-S001:1	37.4	0.75 mm <sup>2</sup> BU	
	+C-S001:1	37.4	+C-S002H:13	37.4		
	+C-S002H:13	37.4	+C-S003H:13	37.4		
	+C-S003H:13	37.4	+C-S004H:13	37.4		
	+C-S004H:13	37.4	+C-S005H:13	37.4		
	+C-S005H:13	37.4	+C-S006:13	37.4		
	+C-XL012:4	001.5	+C-S007:13	37.4	0.75 mm <sup>2</sup> BU	
	+C-S007:13	37.4	+C-S007:23	37.4		
	+C-S007:23	37.4	+C-S008:13	38.4		
	+C-S008:13	38.4	+C-S009:13	38.4		
	+C-XL012:5	001.5	+C-X001:21	39.3	0.75 mm <sup>2</sup> BU	
	+C-XL012:6	001.5	+C-Z001:11	005.6	0.75 mm <sup>2</sup> BU	
	+C-XL012:7	001.5	+C-Q003:13	006.5	0.75 mm <sup>2</sup> BU	
	+C-XL012:8	001.5	+C-X002:1	15.4	0.75 mm <sup>2</sup> BU	
	+C-X002:1	15.4	+C-X002:9	15.4		
	+C-XL012:9	001.5	+C-A102:01	27.1	0.75 mm <sup>2</sup> BU	
	+C-A102:01	27.1	+C-A102:11	28.1		
	+C-A102:11	28.1	+C-A112:09	41.7		

Line	From	Page.Col.	To	Page.Col.	Area/Color	Opt.
	+C-A112:09	41.7	+C-A113:01	44.1		
L50	+C-XL050:1	001.1	+C-Z002:N	005.6	1.5 mm <sup>2</sup> RD	
	+C-XL050:2	001.1	+C-X014:2	009.4	1.5 mm <sup>2</sup> RD	
	+C-XL050:3	001.1	+C-M001:2	009.5	0.75 mm <sup>2</sup> RD	
	+C-XL050:5	001.2	+C-G100:N	007.6	0.75 mm <sup>2</sup> RD	
	+C-XL050:6	001.2	+C-X100:2	12.6	0.75 mm <sup>2</sup> RD	
L51	+C-XL051:1	001.4	+C-K003:3	007.5	1.5 mm <sup>2</sup> RD	
	+C-XL051:3	001.4	+C-X100:1	12.4	0.75 mm <sup>2</sup> RD	
	+C-XL051:4	001.5	+C-M001:1	009.5	0.75 mm <sup>2</sup> RD	
L52	+C-XL052:1	001.7	+C-F003:2	007.5	1.5 mm <sup>2</sup> RD	
	+C-F003:2	007.5	+C-K003:1	007.5		
	+C-XL052:2	001.7	+C-X014:1	009.4	1.5 mm <sup>2</sup> RD	

# 6 Cabinet Terminal Summary

TechPub\_2614345\_v3\_DRAFT\_Release06\_EM2890021\_01.en.fm

### Description

All terminals inside the electrical cabinet are listed in this chapter. The field *Opt.* specifies if the terminal is reserved for an option.

Cabinet terminal summary of 2895133-0003

Terminal	Page .Col.	Opt.
+C-X001:1	006.3	
+C-X001:2	006.3	
+C-X001:3	006.3	
+C-X001:4	006.4	
+C-X001:5		
+C-X001:6		
+C-X001:7	008.2	
+C-X001:8	008.3	
+C-X001:9	008.3	
+C-X001:10	008.4	
+C-X001:11	008.5	
+C-X001:12	26.3	
+C-X001:13	26.3	
+C-X001:14	26.3	
+C-X001:15	26.3	
+C-X001:16	26.3	
+C-X001:17	26.3	
+C-X001:18		
+C-X001:19	26.7	
+C-X001:20	26.7	
+C-X001:21	26.7	
+C-X001:22	39.3	

Terminal	Page .Col.	Opt.
+C-X001:22	39.6	
+C-X001:23	39.3	
+C-X001:24	39.6	
+C-X001:25	39.6	
+C-X001:26	39.6	
+C-X001:27	39.3	
+C-X001:28	39.6	
+C-X001:29	39.6	
+C-X001:30	39.3	
+C-X001:31	39.6	
+C-X001:32		
+C-X001:33	40.3	
+C-X001:34	40.3	
+C-X001:35	40.6	
+C-X001:36	40.3	
+C-X001:37	40.3	
+C-X001:38	40.6	
+C-X001:39		
+C-X001:40		
+C-X001:41		
+C-X001:42		
+C-X001:43		
+C-X001:44		
+C-X001:45	41.2	

Terminal	Page .Col.	Opt.
+C-X001:46	41.6	
+C-X001:47	41.6	
+C-X001:48		
+C-X001:49	27.6	
+C-X001:50	27.3	
+C-X001:51	27.3	
+C-X001:52		
+C-X001:53	27.6	
+C-X001:54	011.2	
+C-X001:55	011.2	
+C-X001:56	011.5	
+C-X001:57	011.5	
+C-X001:58	011.5	
+C-X001:59	011.5	
+C-X001:60	011.5	
+C-X001:61	011.5	
+C-X001:62		
+C-X001:63		
+C-X001:64		
+C-X001:65		
+C-X001:66		
+C-X001:67		
+C-X001:68		
+C-X001:69		

Terminal	Page .Col.	Opt.
+C-X001:70		
+C-X001:71		
+C-X002:1	15.4	
+C-X002:2	15.7	
+C-X002:3	15.7	
+C-X002:4	15.4	
+C-X002:5	15.4	
+C-X002:6	15.4	
+C-X002:7		
+C-X002:8		
+C-X002:9	15.4	
+C-X002:10	15.7	
+C-X002:11	15.7	
+C-X002:12	15.4	
+C-X002:13	15.4	
+C-X002:14	15.4	
+C-X002:15		
+C-X002:16		
+C-X002:17	40.3	
+C-X002:18	40.3	
+C-X002:19	40.6	
+C-X002:20	40.3	
+C-X002:21	40.3	
+C-X002:22	40.6	

Designer	LUP	Date	25/05/2007	Machine	SCUJ4-0150
ECM No	303930	Denomination	CABINET TERMINAL SUMMARY	Page Type	CABINET TERMINAL SUMMARY
Company	Tetra Pak (Italy)	Document No.	2895133-0005	Doc. type	ELD AA
				Version	001

Drawing remarks



# 7 Terminal Strip Overview

TechPub\_2614345\_v3\_DRAFT\_Release07\_EM2890021\_01.en.fm

### Description

All terminals used in the equipment except for those in the electrical cabinet are listed in this chapter.



Terminal strip of 2895133-0003  
+M-X004

From	Cable	Internal Jumper	Terminal	External Jumper	Cable	To	Page.Col.	Option	Function text
+C-X001:11	-W005 :1		1			+M-Y001:1	26 .4		WATER INLET VALVE
+C-X001:19	-W005 :12		1-			+M-Y001:2	26 .6		WATER INLET VALVE
			⊕						
+C-X001:12	-W005 :2	●	2			+M-Y002:1	26 .4		STEAM INLET VALVE
			2-			+M-Y002:2	26 .6		STEAM INLET VALVE
			⊕						
+C-X001:13	-W005 :3	●	3			+M-Y003:1	26 .4		CHANGE OVER VALVE
			3-			+M-Y003:2	26 .6		CHANGE OVER VALVE
			⊕						
+C-X001:14	-W005 :4	●	4			+M-Y004:1	26 .4		DRAINING VALVE
			4-			+M-Y004:2	26 .6		DRAINING VALVE
			⊕						
+C-X001:15	-W005 :5		5			+M-Y005:1	26 .4		FLUSHING VALVE ALKALI PUMP
			5-			+M-Y005:2	26 .6		FLUSHING VALVE ALKALI PUMP
			⊕						
+C-X001:16	-W005 :6		6			+M-Y006:1	26 .4		CHANGE OVER VALVE FILLER 2
+C-X001:20	-W005 :13		6-			+M-Y006:2	26 .6		CHANGE OVER VALVE FILLER 2
			⊕						
+C-X001:17	-W005 :7		7				26 .4		
			7-						
			⊕						
			8						
			8-						
			⊕						
			9						
			9-						
			⊕						
			10						
			10-						
			⊕						

Designer LUP	Date 25/05/2007	Machine SCU4-0150
ECM No 303930	Denomination TERMINAL STRIP OVERVIEW	Page type TERMINAL STRIP OVERVIEW
	Document No. 2895133-0006	Doc. type ELD
Company Tetra Pak (Italy)		Version AA
		Page 002

Drawing remarks





# 8 Cable Connection List

TechPub\_2614345\_v3\_DRAFT\_Release08\_EM2890021\_01.en.fm

**Description**

All cable connections used in the equipment are listed in this chapter.

TechPub\_2614345\_v3\_DRAFT\_Release08\_EM2890021\_01.en.fm















Cable Connection List of 2895133-0003

From	Cable	To	Page.Col.	Option	From	Cable	To	Page.Col.	Option
+C-A001:43	+C-W026 WH BN SH	+C-A112:1039	+C/41.07		+C-X001:10	2	+M-M003:2	+C/008.04	
					+C-X001:11	GNYE	+M-M003:3	+C/008.04	
						+M-W005			
+C-A113:AI001	+C-W027 WH BN SH	+C-A001:31	+C/010.03		+C-X001:12	1	+M-X004:1	+C/26.03	
+C-A113:AI002		+C-A001:33	+C/010.03		+C-X001:13	2	+M-X004:2	+C/26.03	
		GND:	+C/010.03		+C-X001:14	3	+M-X004:3	+C/26.03	
					+C-X001:15	4	+M-X004:4	+C/26.03	
+C-X003:5	+C-W028 WH BN SH	+C-A113:-	+C/43.05		+C-X001:16	5	+M-X004:5	+C/26.03	
+C-X003:3		+C-A113:-	+C/43.05		+C-X001:17	6	+M-X004:6	+C/26.03	
						7	+M-X004:7	+C/26.03	
						8			
						9			
+C-X003:6	+C-W029 WH BN SH	+C-A001:32	+C/010.03			10			
+C-X003:4		+C-A001:34	+C/010.03			11			
		GND:	+C/010.03			12	+M-X004:1-	+C/26.07	
						13	+M-X004:6-	+C/26.07	
						GNYE	+C-X001:3	+C/26.07	
						+M-W006			
+C-X001:1	+M-W001 1	+M-M001:U	+C/006.03		+C-X001:22	BU	+M-B002:2	+C/39.05	
+C-X001:2	2	+M-M001:V	+C/006.03		+C-X001:21	BU	+M-B002:1	+C/39.03	
+C-X001:3	3	+M-M001:W	+C/006.03			+M-W007			
+C-X001:3	GNYE	+M-M001:3	+C/006.03			YE	+M-X003:1	+C/39.03	
						WH	+M-X003:2	+C/39.06	
+C-X001:7	+M-W002 1	+M-M002:1	+C/008.02			GN	+M-X003:3	+C/39.06	
+C-X001:8	2	+M-M002:2	+C/008.02			RD	+M-X003:4	+C/39.06	
+C-X001:8	GNYE	+M-M002:3	+C/008.02			+M-W008			
+C-X001:8						1	+M-X008:1	+C/39.03	
						2	+M-X008:2	+C/39.05	
						GNYE	+M-X008:3	+C/39.05	
+C-X001:9	+M-W003 1	+M-M003:1	+C/008.04						

Cable Connection List of 2895133-0003

From	Cable	To	Page.Col.	Option	From	Cable	To	Page.Col.	Option
+C-X001:29	+M-W009 1	+M-X009:1	+C/39.03		+C-X001:55	+M-W017 1	+M-B015:17	+C/011.05	FLOW
+C-X001:30	2	+M-X009:2	+C/39.05		+C-X001:57	3	+M-B015:6	+C/011.05	FLOW
+C-X001:31	GNYE	+M-X009:3	+C/39.05		+C-X001:58	4	+M-B015:7	+C/011.05	FLOW
+C-X001:33	+M-W011 BN	+M-B007:	+C/40.04		+C-X001:59	5	+M-B015:8	+C/011.05	FLOW
+C-X001:34	BU	+M-B007:	+C/40.04		+C-X001:60	6		+C/011.05	FLOW
+C-X001:35	BK	+M-B007:	+C/40.05		+C-X001:61	GNYE		+C/011.05	FLOW
+C-X001:36	+M-W012 BN	+M-B008:	+C/40.04		+C-X001:62	2	+M-B015:4	+C/011.03	FLOW
+C-X001:37	BU	+M-B008:	+C/40.04		+C-X002:1	+M-W018 1	+C-FILLER001:	+C/15.05	
+C-X001:38	BK	+M-B008:	+C/40.05		+C-X002:2	2	+C-FILLER001:	+C/15.06	
+C-X001:45	+M-W015 1	+M-S001H:13	+C/41.03		+C-X002:3	GNYE	+C-FILLER001:	+C/15.06	
+C-X001:46	2	+M-S001H:14	+C/41.05		+C-X002:9	+M-W019 1	+C-FILLER002:	+C/15.05	
+C-X001:47	3	+M-S002H:14	+C/41.05		+C-X002:10	2	+C-FILLER002:	+C/15.06	
+C-X001:49	4				+C-X002:19	GNYE	+C-FILLER002:	+C/15.06	
+C-X001:50	5	+M-H001S:11	+C/27.06		+C-X002:17	+M-W020 BN	+M-B010:	+C/40.04	2-MACH
+C-X001:51	6	+M-H001S:12	+C/27.04		+C-X002:18	BU	+M-B010:	+C/40.04	2-MACH
	7	+M-H002S:12	+C/27.04		+C-X002:21	BK	+M-B010:	+C/40.05	2-MACH
	8				+C-X002:20	+M-W021 BN	+M-B011:	+C/40.04	2-MACH
	9				+C-X002:21	BU	+M-B011:	+C/40.04	2-MACH
	10				+C-X002:22	BK	+M-B011:	+C/40.05	2-MACH
	11					+M-W022 4	+C-FILLER001:	+C/15.05	
+C-X001:53	+M-W016 1	+M-B015:1	+C/011.02	FLOW	+C-X002:6	3	+C-FILLER001:	+C/15.05	
+C-X001:54	2	+M-B015:2	+C/011.02	FLOW	+C-X002:5	2	+C-FILLER001:	+C/15.05	
+C-X001:55	GNYE		+C/011.02	FLOW	+C-X002:4				

Cable Connection List of 2895133-0003

From	Cable	To	Page.Col.	Option	From	Cable	To	Page.Col.	Option
+C-X002:3	 1	+C-FILLER001:	+C/15.05						
+C-X002:14	 4	+C-FILLER002:	+C/15.05						
+C-X002:13	 3	+C-FILLER002:	+C/15.05						
+C-X002:12	 2	+C-FILLER002:	+C/15.05						
+C-X002:11	 1	+C-FILLER002:	+C/15.05						
	 +M-W025								
+C-A001:15	 WH		+C/010.04						
+C-A001:84	 BL	+M-B001:	+C/010.04						
+C-A001:12	 WH	+M-B001:	+C/010.04						
+C-A001:13	 YE	+M-B001:	+C/010.04						
+C-A001:11	 GN	+M-B001:	+C/010.04						
+C-A001:16	 RD		+C/010.04						
+C-A001:83	 BL	+M-B001:	+C/010.04						
	 SH	GND:	+C/010.04						

---

This page intentionally left blank

# 9 Mains Connections

TechPub\_2614345\_v3\_DRAFT\_Release09\_EM2890021\_01.en.fm

### Description

The drawings that show the connection from the mains power to the electrical cabinet are included in this chapter.

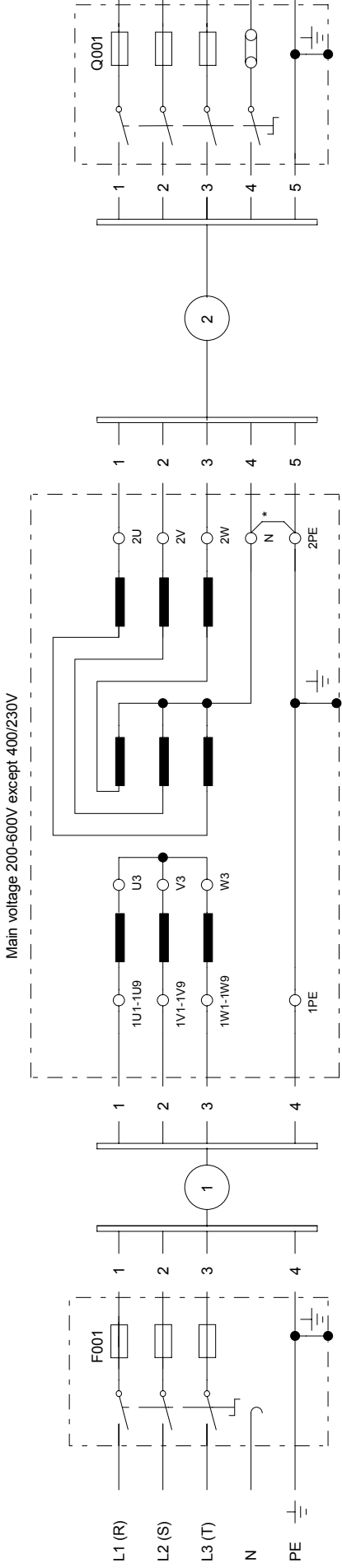

\* NOTE: Make sure that the bridge is connected.

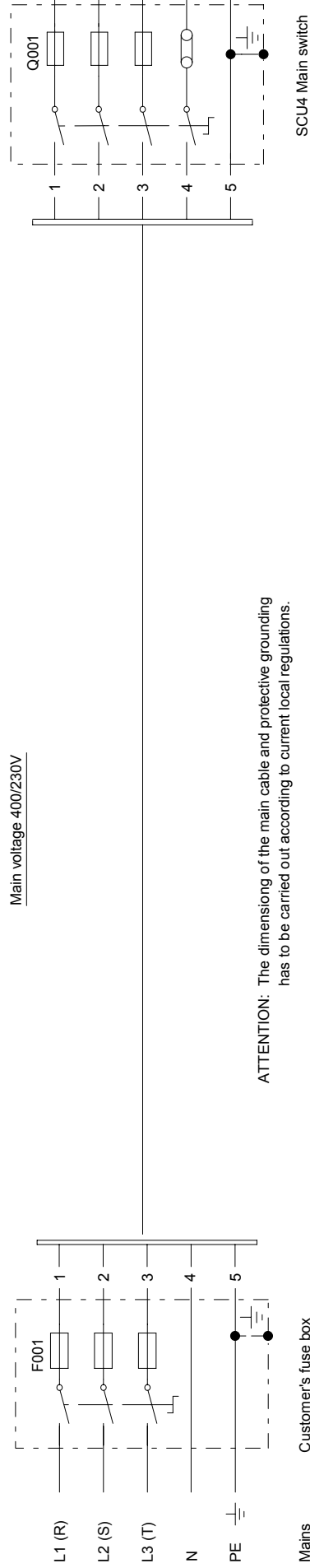

ATTENTION: The dimensioning of the main cable and protective grounding has to be carried out according to current local regulations.

		Designer LUP ECM No 303930	Date 25/05/2007	Machine SCU4-0150
Company Tetra Pak (Italy)		Denomination MAINS CONNECTION		
Drawing remarks		Document No. 2895133-0008		
		Doc. type ELD	Version AA	Page 001

---

This page intentionally left blank

# 10 Drawing Remarks

TechPub\_2614345\_v3\_DRAFT\_Release10\_EM2890021\_01.en.fm

### Description

The following pages contain the drawing remarks referenced in chapter 4 Circuit Diagrams.

Drawing No.	Page	Note	Remark
2895133-0003	010	1	GND CONNECTED TO CHASSIS.
	011	1	WIRES MARKED WITH P001 TERMINAL NUMBERS TO BE REMOVED AT FLOW METER INSTALLATION.
		2	TO BE DONE AT FLOW METER INSTALLATION.
		3	SUPPLIED WITH THE COMPONENT.
	012	1	WIRES MARKED WITH P001 TERMINAL NUMBERS.
		2	BRIDGES TO BE DONE AT RECORDER INSTALLATION.
		3	GND CONNECTED TO CHASSIS.
	015	1	TO BE USED IN A SINGLE FILLER INSTALLATION.
		2	TO BE USED IN A MULTI-FILLER INSTALLATION ONLY.
		3	RECOMMENDED CABLE OILFLEX 7x0.75mm <sup>2</sup> TP.351150-406.
	040	1	TO BE REMOVED IN A MULTI-FILLER INSTALLATION.
	042	1	INPUT ALWAYS ENERGIZED IF FLOW METER IS NOT INSTALLED.
	044	1	CLAMPED IN THE SWING FRAME.

**Tetra Pak (Italy)**

Issued by/Date: ZM / 2007-05-25

Approved/Date: ZM / 2007-05-25

ECM 303930

**Drawing remarks**

Identity	Document type	Version	Page
2895133-0098	ELD	AA	1(1)

---

This page intentionally left blank

# 11 Engineering Change Description

TechPub\_2614345\_v3\_DRAFT\_Release11\_EM2890021\_01.en.fm

### Description

This chapter describes the changes introduced with the ECM.

---

ECM No.	Drawing No.	Alteration
303930		DOCUMENTATION INTRODUCED.

This drawing must not without the consent of Tetra Pak be copied, transmitted or disclosed to any third party.

---

**Tetra Pak (Italy)**

Issued by/Date: ZM / 2007-05-25

Approved/Date: 2007-05-25

ECM 303930

**Engineering Change Description**

Identity	Document type	Version	Page
2895133-0099	ELD	AA	1(1)

---

This page intentionally left blank

# 12 Component Location

TechPub\_2614345\_v3\_DRAFT\_Release12\_EM2890021\_01.en.fm

### Description

The location of all components can be found in the Spare Parts Catalogue.

# 13 Other Information

### Description

This chapter is used for Bills of Material, Fuse Panel Labels, and so on.

**13.1 Bills of Material . . . . . 13 - 5**

**13.2 Fuse Panel Label . . . . . 13 - 7**

TechPub\_2614345\_v3\_DRAFT\_Release13\_EM2890021\_01.en.fm

This page intentionally left blank

TechPub\_2614345\_v3\_DRAFT\_Release13\_EM2890021\_01.en.fm

## 13.1 Bills of Material

This chapter included the lists of the documents and programs.

TechPub\_2614345\_v3\_DRAFT\_Release13\_EM2890021\_01.en.fm

This page intentionally left blank

TechPub\_2614345\_v3\_DRAFT\_Release13\_EM2890021\_01.en.fm

ECM P311100(L303931)  
 Release date 2007.05.31

ChgPosition	S p	S H	Description	A S i s e	Identity	D T p	P r t	V s	U n	Column quantity	ECM
I 0010			ELECTRICAL DOCUMENT	X	2908508-0100				PC	1	311100
I 0020			Software PLC	X	2905415-0100				PC	1	311100

ECM P304453(L303931)  
 Release date 2007.05.31

ChgPosition	S p	S H	Description	A S i s e	Identity	D T p	P r t	V s	U n	Column quantity	ECM
I	0010		Label CD		2895450-0001				PC	1	304453
I	0020		Program Object Code		1591306-1001				PC	1	304453
I	0030		COMPACT DISC RECORDABLE	A4	90458-0118				PC	1	304453

ECM P310413(L303931)  
Release date 2007.05.31

ChgPosition	S	S	H	Description	A	Si	Identity	D	Tp	Prt	Vs	Un	Column	quantity	ECM
	p				s	ze						it	All		
I 0010				PLC CD	Y		1591306-0001					PC	1		310413

ECM P311094(L303931)  
 Release date 2007.05.31

ChgPosition	S p	S H	Description	A S i s e	I d e n t i t y	D T p	P r t	V s	U n i t	C o l u m n	q u a n t i t y	ECM
I	0010		DOCUMENTS LIST		2895133-0001	ELD	000	AA		X		311094
I	0020		POSITION SUMMARY		2895133-0002	ELD	000	AA		X		311094
I	0030		CIRCUIT DIAGRAM		2895133-0003	ELD	000	AA		X		311094
I	0040		LINE SUMMARY		2895133-0004	ELD	000	AA		X		311094
I	0050		CABINET TERMINAL SUMMARY		2895133-0005	ELD	000	AA		X		311094
I	0060		TERMINAL STRIP OVERVIEW		2895133-0006	ELD	000	AA		X		311094
I	0070		CABLE CONNECTION LIST		2895133-0007	ELD	000	AA		X		311094
I	0080		MAINS CONNECTION		2895133-0008	ELD	000	AA		X		311094
I	0098		DRAWING REMARKS		2895133-0098	ELD	000	AA		X		311094
I	0099		ENGINEERING CHANGE DESCRIPTION		2895133-0099	ELD	000	AA		X		311094

## 13.2 Fuse Panel Label

This chapter shown the location and the setting of the fuses.

TechPub\_2614345\_v3\_DRAFT\_Release13\_EM2890021\_01.en.fm

This page intentionally left blank

TechPub\_2614345\_v3\_DRAFT\_Release13\_EM2890021\_01.en.fm

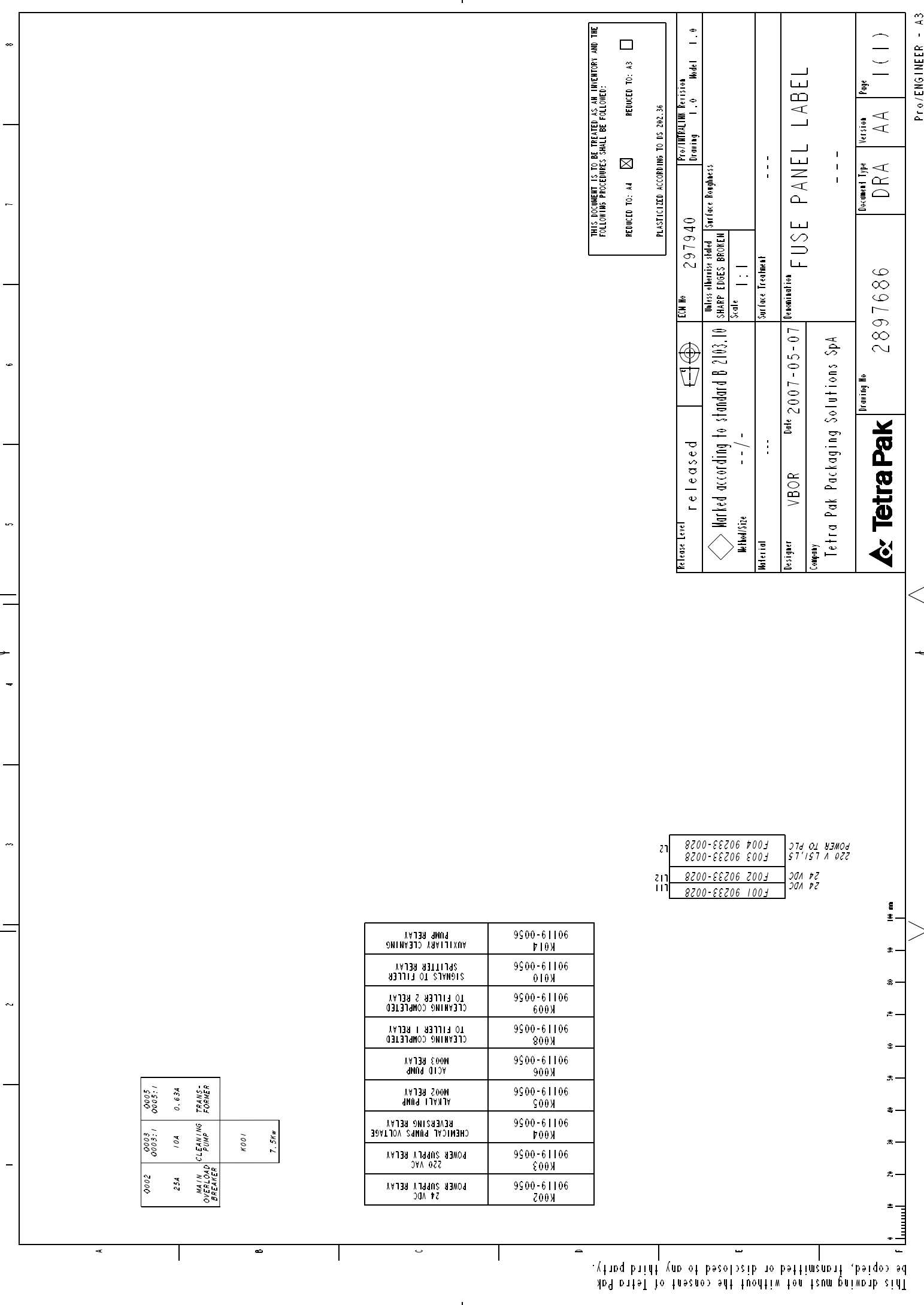

0002	0003 0003:1	0005 0005:1
254	10A	0.63A
MAIN CLEANING PUMP SPLITTER		
R001		7.5kw

K002	24 VDC	90119-0056	POWER SUPPLY RELAY
K003	220 VAC	90119-0056	POWER SUPPLY RELAY
K004	CHEMICAL PUMPS VOLTAGE	90119-0056	REVERSING RELAY
K005	ALKALI PUMP	90119-0056	M002 RELAY
K006	ACID PUMP	90119-0056	M003 RELAY
K008	CLEANING COMPLETED	90119-0056	TO FILLER 1 RELAY
K009	CLEANING COMPLETED	90119-0056	TO FILLER 2 RELAY
K010	SIGNALS TO FILLER	90119-0056	SPLITTER RELAY
K014	AUXILIARY CLEANING	90119-0056	PUMP RELAY

L11	F001 90233-0028	24 VDC
L12	F002 90233-0028	24 VDC
L2	F003 90233-0028	220 V L51, L5
	F004 90233-0028	POWER TO PLC

This drawing must not without the consent of Tetra Pak be copied, transmitted or disclosed to any third party.

THIS DOCUMENT IS TO BE TREATED AS AN INVENTORY AND THE FOLLOWING PROCEDURES SHALL BE FOLLOWED:  
 REDUCED TO: A4  REDUCED TO: A3   
 PLASTICIZED ACCORDING TO DS 202.36

Release Level	released	ECN No	297940	Pro/INITIALING	Revision	Model	I . 0
Marked according to standard B 2103.10 Method/site: - - / - - Material: - - - - Designer: VBOR Date: 2007-05-07 Company: Tetra Pak Packaging Solutions Spa	Unless otherwise stated SHARP EDGES BROKEN Scale: 1 : 1 Surface Treatment: - - - -	Drawing	I . 0	Document Type	DRA	Version	AA
		Denomination	FUSE PANEL LABEL			Page	I ( I )
Tetra Pak		Drawing No	2897686				

---

This page intentionally left blank





**SCU/4**

**616054-0150**

Issue 2007-05 Doc. No. EM-2890021-0101

**SCU/4 1(2)**

**616054-0150**

Issue 2007-05 Doc. No. EM-2890021-0101

**SCU/4**

**616054-0150**

Issue 2007-05 Doc. No. EM-2890021-0101

**SCU/4 1(2)**

**616054-0150**

Issue 2007-05 Doc. No. EM-2890021-0101

**SCU/4**

**616054-0150**

Issue 2007-05 Doc. No. EM-2890021-0101

**SCU/4 1(2)**

**616054-0150**

Issue 2007-05 Doc. No. EM-2890021-0101

**SCU/4**

**616054-0150**

Issue 2007-05 Doc. No. EM-2890021-0101

**SCU/4 1(2)**

**616054-0150**

Issue 2007-05 Doc. No. EM-2890021-0101

**SCU/4**

**616054-0150**

Issue 2007-05 Doc. No. EM-2890021-0101

**SCU/4 2(2)**

**616054-0150**

Issue 2007-05 Doc. No. EM-2890021-0101

**SCU/4**

**616054-0150**

Issue 2007-05 Doc. No. EM-2890021-0101

**SCU/4 2(2)**

**616054-0150**

Issue 2007-05 Doc. No. EM-2890021-0101

**SCU/4**

**616054-0150**

Issue 2007-05 Doc. No. EM-2890021-0101

**SCU/4 2(2)**

**616054-0150**

Issue 2007-05 Doc. No. EM-2890021-0101

**SCU/4**

**616054-0150**

Issue 2007-05 Doc. No. EM-2890021-0101

**SCU/4 2(2)**

**616054-0150**

Issue 2007-05 Doc. No. EM-2890021-0101

**SCU/4**  
616054-0150

Issue 2007-05 Doc. No. EM-2890021-0101

**SCU/4 1(2)**  
616054-0150

Issue 2007-05 Doc. No. EM-2890021-0101

**SCU/4**  
616054-0150

Issue 2007-05 Doc. No. EM-2890021-0101

**SCU/4 1(2)**  
616054-0150

Issue 2007-05 Doc. No. EM-2890021-0101

**SCU/4**  
616054-0150

Issue 2007-05 Doc. No. EM-2890021-0101

**SCU/4 1(2)**  
616054-0150

Issue 2007-05 Doc. No. EM-2890021-0101

**SCU/4**  
616054-0150

Issue 2007-05 Doc. No. EM-2890021-0101

**SCU/4 2(2)**  
616054-0150

Issue 2007-05 Doc. No. EM-2890021-0101

**SCU/4**  
616054-0150

Issue 2007-05 Doc. No. EM-2890021-0101

**SCU/4 2(2)**  
616054-0150

Issue 2007-05 Doc. No. EM-2890021-0101

**SCU/4**  
616054-0150

Issue 2007-05 Doc. No. EM-2890021-0101

**SCU/4 2(2)**  
616054-0150

Issue 2007-05 Doc. No. EM-2890021-0101